

# Infinite Gabriel-Roiter measures for the 3-Kronecker quiver

Dissertation zur Erlangung des Doktorgrades  
der Fakultät für Mathematik

Universität Bielefeld

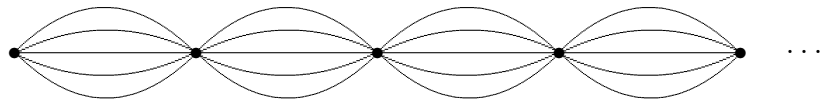

Philipp Fahr

January 2008

1. **Gutachter:** Prof. Dr. Dr. h.c. Claus Michael Ringel
  2. **Gutachter:** Dr. Rolf Farnsteiner
- Tag der mündlichen Prüfung:** 31. März 2008

LE BUT UNIQUE DE LA SCIENCE, C'EST L'HONNEUR DE L'ESPRIT HUMAIN,  
ET SOUS CE TITRE, UNE QUESTION DE NOMBRES VAUT AUTANT  
QU'UNE QUESTION DU SYSTÈME DU MONDE.

(Lettre de Carl Gustav Jacob Jacobi du  
2 juillet 1830 adressé à Legendre)

# Contents

<b>1</b>	<b>Introduction</b>	<b>1</b>
1.1	The 3-Kronecker quiver . . . . .	4
1.2	Tits & Ringel form . . . . .	4
1.3	Wild algebras . . . . .	5
1.4	Kac's Theorem . . . . .	6
1.5	Reflections . . . . .	7
1.6	Coxeter functors . . . . .	10
<b>2</b>	<b>Tools &amp; Visualization</b>	<b>12</b>
2.1	Process of Simplification . . . . .	12
2.2	Coefficient quivers . . . . .	12
2.3	Universal Covering . . . . .	14
<b>3</b>	<b>Gabriel-Roiter measure</b>	<b>17</b>
3.1	Radical & socle series . . . . .	17
3.2	Definitions & notations . . . . .	17
3.3	Basic properties . . . . .	18
3.4	Preprojective modules . . . . .	20
<b>4</b>	<b>An infinite Gabriel-Roiter filtration from the 2-Kronecker quiver</b>	<b>21</b>
4.1	Construction of $R[n]$ . . . . .	21
4.2	Proof of Lemma 4.1 . . . . .	22
<b>5</b>	<b>Uniserial and piling modules</b>	<b>24</b>
5.1	Uniserial modules . . . . .	24
5.2	Piling submodules . . . . .	24
<b>6</b>	<b>Construction of uncountably many Gabriel-Roiter measures</b>	<b>26</b>
6.1	General Structure Lemma . . . . .	27
6.2	Simple socle submodules of $R[n]_I$ . . . . .	28
6.3	Proof of theorem 6.1 . . . . .	31
6.4	The Gabriel-Roiter measure depends on $I$ . . . . .	36
6.5	Case $I = \mathbb{N}_1$ . . . . .	37
6.6	$R[n]_I$ and dimension vectors . . . . .	39
6.7	Uncountably many Gabriel-Roiter measures . . . . .	40
6.7.1	Infinite Gabriel-Roiter filtration . . . . .	40
6.7.2	Definition of $R[\infty]_I$ . . . . .	40
6.7.3	Uncountably many $R[\infty]_I$ . . . . .	41
<b>7</b>	<b>Link to Fibonacci numbers</b>	<b>43</b>
7.1	Slope for the 3-Kronecker . . . . .	44
7.2	Dimension vectors . . . . .	44
7.3	Gabriel-Roiter measure of $\mathcal{D}$ . . . . .	47

<b>8</b>	<b>A partition formula for Fibonacci numbers</b>	<b>50</b>
<b>9</b>	<b>Morphisms between regular modules</b>	<b>57</b>
9.1	Elementary modules . . . . .	58
9.2	Matrices . . . . .	59
9.3	Chain of elementary modules . . . . .	65
<b>A</b>	<b>Maple source code</b>	<b>68</b>
A.1	Computing the Auslander-Reiten translate . . . . .	68
A.2	Plotting coefficient quivers . . . . .	71
<b>B</b>	<b>References</b>	<b>75</b>

## Abstract

In this thesis we will use indecomposable representations of the 3-Kronecker quiver to construct uncountably many infinite Gabriel-Roiter measures. Our aim is to classify all piling submodules of an indecomposable regular module. We will show that they are either unique of a certain length or there is a one-parameter family of such submodules. The 3-regular tree will help to visualise these representations in the universal cover of the 3-Kronecker quiver. This also gives a combinatorial link to an interesting sum partition of the Fibonacci numbers. A possible largest Gabriel-Roiter measure in the central part is discussed.

*Keywords:* Quiver, Gabriel-Roiter measure, coefficient quiver, 3-regular tree, extended Kronecker quiver, Fibonacci numbers.

2000 *Mathematics Subject Classification.* Primary: 16G20; Secondary: 16G60, 16D90.

## 1 Introduction

This thesis will investigate the Gabriel-Roiter measure of indecomposable regular representations of the 3-Kronecker quiver, having two vertices and three arrows in the same direction. We will construct uncountably many infinite Gabriel-Roiter measures. This is done using *piling submodules*, which are introduced in chapter 5. Our aim is to classify all piling submodules of a particular indecomposable regular module and we will show that they are either unique of a certain length or there is a one-parameter family of such submodules.

C.M. Ringel has conjectured that there are only countably many Gabriel-Roiter measures in the case of a tame algebra. There exists an unpublished result establishing the tame hereditary case. We will consider the wild hereditary 3-Kronecker quiver and we will determine Gabriel-Roiter measures of regular representations whose dimension vectors lie in a certain range.

A new link to the Fibonacci numbers giving an interesting sum partition of the Fibonacci numbers will be explored using the infinite 3-regular tree, which is the universal cover of the 3-Kronecker quiver. It is the 3-Cayley tree without leaves, and a Bruhat-Tits tree. Apparently this is also known as the *Bethe lattice* with coordination number 3 in the theory of exactly solvable models.

Recall that a finite-dimensional algebra is said to be of *finite representation type* if there are only finitely many indecomposable modules of finite length. Then any module is the direct sum of modules of finite length (Ringel-Tachikawa, 1974) and such a decomposition is unique up to isomorphism.

Maurice Auslander has shown (in “Large modules over artin algebras”, 1976) that if  $A$  is not of finite representation type, then there exist indecomposable

modules which are not of finite length. Auslander gave an existence proof and C. M. Ringel gave a general structure theory for modules of arbitrary length in his “Rome Lectures” (1977, published 1979 [Ri5]). He showed that there always will be certain important infinite-dimensional representations and the investigation of these representations also gives some new insight into the behaviour of the modules of finite length.

While constructing infinite-dimensional representations for the 3-Kronecker quiver, their Gabriel-Roiter measures are determined. These will be infinite Gabriel-Roiter measures lying in the central part of the module category, which was introduced by C. M. Ringel in his theory on the Gabriel-Roiter measure (see [Ri3] and [Ri4]).

This thesis is structured as follows: after giving some definitions and basic results in the first chapter, we will present in chapter 2 the the *Process of Simplification*, as well as a method to visualise representations known as *coefficient quivers*. We then introduce the *Gabriel-Roiter measure* of a module, an invariant determined by the submodule structure of a module. This is done in chapter 3, where we also give basic properties of this invariant. Chapters 4 and 6 form the core of the thesis, where uncountably many infinite Gabriel-Roiter measures are constructed for the 3-Kronecker quiver. In chapter 5 *piling submodules* are introduced: they are the key tool for the proofs of chapter 6. We then turn our interest to the link to Fibonacci numbers in chapter 7. We will also discuss a sequence of dimension vectors for which many combinatorial properties will be shown, leading to a conjecture on the largest Gabriel-Roiter measure in the central part. The new sum partition formula for odd index Fibonacci numbers is presented in chapter 8. Finally, the last chapter 9 collects some more evidence for the conjecture to be true. It also presents module-theoretical structure for the possible largest Gabriel-Roiter measure in the central part, pointing out an interesting connection to elementary modules as introduced by O. Kerner ([K1]) and F. Lukas ([L2]).

## Acknowledgements

First and foremost I would like to thank my supervisor, Professor Dr. Dr. h. c. Claus Michael Ringel, for his continued advice, patience, encouragement and academic freedom he gave me during my time in Bielefeld. I owe him everything in mathematics and a lot in life, which he shaped in many ways. It has been an honour and a great pleasure to work together with him and I thank him to have made my participation at numerous conferences possible. During the end of writing up this thesis he showed in particular his qualities as a supervisor.

I would also like to thank my parents and my family for their unconditional support throughout my time at university. Without the financial support much of what I achieved would not have been possible.

Thank you to all present and past members of the BIREP research group at the University of Bielefeld, especially Chen Bo, Henning Krause, Andrew Hubery, Dieter Vossieck and Abdukader Obul. I also thank Otto Kerner for his help and discussions.

Finally, I would like to thank the Friedrich-Ebert-Stiftung and the Faculty of Mathematics of the University of Bielefeld for their financial support during parts of my PhD.

But most importantly I thank my fiancée, Tina Hapke, who suffered with me for so long — what would my life be without you and Maxi.

## 1.1 The 3-Kronecker quiver

The 3-Kronecker quiver  $K(3)$  is the following quiver with two vertices and three arrows in the same direction:

$$K(3) : 1 \bullet \begin{array}{c} \xrightarrow{\alpha} \\ \xrightarrow{\beta} \\ \xrightarrow{\gamma} \end{array} \bullet 2$$

Let  $kK(3)$  be the path algebra of the quiver  $K(3)$ , where  $k$  is an algebraically closed field. Throughout (unless otherwise stated) we will let  $A = kK(3)$ . A representation of  $K(3)$  is of the form  $(V_1, V_2; \alpha, \beta, \gamma)$ , where  $V_1, V_2$  are  $k$ -vector spaces and  $\alpha, \beta, \gamma : V_2 \rightarrow V_1$  are three linear transformations.  $A$  is a connected wild hereditary algebra, which is finite-dimensional and has basis  $\{e_1, e_2, \alpha, \beta, \gamma\}$ , where  $e_1, e_2$  are the trivial paths at vertices  $v_1, v_2$  respectively.

For the quiver  $K(3)$  we have two simple modules  $S_1, S_2$  with dimension vectors  $\mathbf{dim} S_1 = (1, 0)$  and  $\mathbf{dim} S_2 = (0, 1)$ . We also have two projective modules  $P_1, P_2$  and two injective modules  $I_1, I_2$  with the following dimension vectors respectively:  $\mathbf{dim} P_1 = (1, 0)$ ,  $\mathbf{dim} P_2 = (3, 1)$ , and  $\mathbf{dim} I_1 = (0, 1)$ ,  $\mathbf{dim} I_2 = (1, 3)$ . The Cartan matrix associated to the path algebra of the quiver  $K(3)$  is

$$C_A = \begin{bmatrix} 1 & 3 \\ 0 & 1 \end{bmatrix}, \text{ so } C_A^{-t} = \begin{bmatrix} 1 & 0 \\ -3 & 1 \end{bmatrix},$$

and the Coxeter transformation is:

$$\Phi = -C_A^{-t}C_A = \begin{bmatrix} -1 & -3 \\ 3 & 8 \end{bmatrix}, \text{ with inverse } \Phi^{-1} = \begin{bmatrix} 8 & 3 \\ -3 & -1 \end{bmatrix}.$$

Since  $A$  is a hereditary algebra, we have  $\mathbf{dim} \tau M = \Phi(\mathbf{dim} M)$  for any indecomposable module  $M$ , which is not projective. Similarly, for any indecomposable non-injective module  $N$ , we have  $\mathbf{dim} \tau^{-1} N = \Phi^{-1}(\mathbf{dim} N)$ .

## 1.2 Tits & Ringel form

Let  $K(\text{mod } A)$  be the Grothendieck group of  $\text{mod } A$  with respect to all short exact sequences. Thus  $K(\text{mod } A)$  can be identified with the free abelian group generated by the isomorphism classes of simple modules. The canonical map from  $\text{mod } A$  into  $K(\text{mod } A)$  will be denoted by  $\mathbf{dim}$ . The Ringel form is the bilinear form on  $K(\text{mod } A)$  given by:

$$\langle \mathbf{dim} X, \mathbf{dim} Y \rangle = \dim_k \text{Hom}(X, Y) - \dim_k \text{Ext}(X, Y),$$

since  $\text{mod } A$  is hereditary. We will usually denote  $\langle \mathbf{dim} X, \mathbf{dim} Y \rangle$  just by  $\langle X, Y \rangle$ . For the quiver  $K(3)$  we have the following bilinear form  $(-, -) : \mathbb{Z}^2 \times \mathbb{Z}^2 \rightarrow \mathbb{Z}$  given by  $(x, y) = xC_A^{-t}y = (x_1 - 3x_2)y_1 + x_2y_2$ , where  $x = (x_1, x_2)$ ,  $y = (y_1, y_2) \in \mathbb{Z}^2$ . Hence the Tits form is  $q(x) := (x, x) = x_1^2 + x_2^2 - 3x_1x_2$ .

Given a representation of the quiver  $K(3)$  of dimension vector  $(n, m)$ , then  $\alpha, \beta, \gamma$  are  $m \times n$ -matrices. The set of all representations of dimension vector

$(n, m)$  will be denoted by  $\mathcal{R}(n, m)$ . It is an affine space over  $k$  of dimension  $3nm$ . The isomorphism classes are just the orbits in  $\mathcal{R}(n, m)$  of the obvious action by the algebraic group  $GL_n(k) \times GL_m(k)$ . Consider the quadratic form  $q(x, y) = x^2 + y^2 - 3xy$  associated to the quiver  $K(3)$ . The integral vectors  $(x, y)$  with  $q(x, y) \leq 0$  are called *imaginary roots*; those with  $q(x, y) = 1$  are called *real roots*.

According to Kac, for any positive real root  $d$ , there is an indecomposable module  $M$  in  $\text{mod } A$  with  $\mathbf{dim} M = d$ , and this module is unique up to isomorphism. We call those modules *real root modules*. One is also interested in the structure of the endomorphism ring  $\text{End}(M)$ .

Let us also recall the real roots for the 3-Kronecker quiver:

$$(1, 0), (3, 1), (8, 3), (21, 8), (55, 21), \dots$$

$$(0, 1), (1, 3), (3, 8), (8, 21), (21, 55), \dots$$

The upper sequence gives the dimension vectors of the indecomposable preprojective modules. The lower sequence gives the dimension vectors of the indecomposable preinjective modules. The imaginary roots of the 3-Kronecker quiver are all  $(n, m) \in \mathbb{N}_1^2$  with

$$\frac{3 - \sqrt{5}}{2} < \frac{n}{m} < \frac{3 + \sqrt{5}}{2}.$$

We will look at the imaginary roots more closely in chapter 7.

### 1.3 Wild algebras

Let us recall that an algebra is called *representation-infinite* provided there are infinitely many isomorphism classes of indecomposable modules. Otherwise an algebra is called *representation-finite*. Representation-infinite algebras can further be divided into the class of *tame* and *wild* algebras, which is defined as follows:

**Definition 1.1.** *A finite-dimensional hereditary  $k$ -algebra  $B$  is called wild hereditary, provided for any finite-dimensional  $k$ -algebra  $C$ , there exists a full exact embedding  $F_C : \text{mod } C \rightarrow \text{mod } B$ , where  $\text{mod } C$ , respectively  $\text{mod } B$  denotes the categories of finite-dimensional  $C$  respectively  $B$ -modules*

Recall that 3-Kronecker quiver is a wild quiver and its path algebra a wild hereditary algebra. An indecomposable representation  $M$  is said to be *exceptional*, provided  $\text{Ext}_A^1(M, M) = 0$ . The exceptional  $A$ -modules are the preprojective and the preinjective modules as shown in [Ri8].<sup>1</sup> Ringel<sup>2</sup> has shown, that for an algebra with more than two simple modules, there always exist regular exceptional modules, that is regular stones. In our case however the preprojective and preinjective modules are the only stones.

<sup>1</sup>From C.M. Ringel [Ri8] we know, that the wild algebra  $A$  having two simple modules has no regular stones (i.e. indecomposable modules without self-extensions, which are bricks).

<sup>2</sup>In *The regular components of the Auslander-Reiten quiver of a tilted algebra*. Chinese Ann. Math. B. 9 (1988), 1-18.

A connected component  $\mathcal{C}$  of the Auslander-Reiten quiver  $\Gamma(A)$  is called *regular*, if  $\mathcal{C}$  contains neither projective nor injective vertices. Any regular component of a basic wild hereditary algebra which is connected has the shape  $\mathbb{Z}A_\infty$ . The category of all regular  $A$ -modules will be denoted by  $A\text{-reg}$ . This category is not an abelian category. Figure 1 shows the shape of any regular component in the Auslander-Reiten quiver of a wild hereditary algebra.

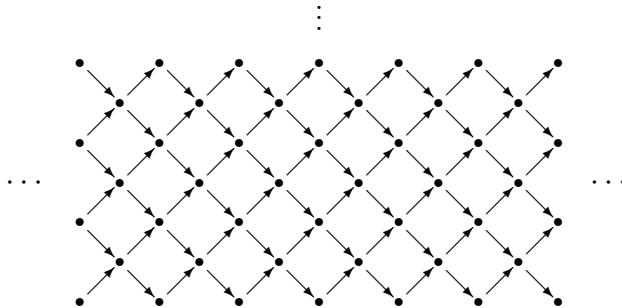

Figure 1: A regular component in the Auslander-Reiten quiver of a finite-dimensional wild hereditary algebra.

## 1.4 Kac's Theorem

Let us recall Kac's Theorem on the existence of indecomposable representations and number of parameters. Let  $Q = (Q_0, Q_1)$  be a quiver without loops and  $\mathbf{d} = (d_i)_{i \in Q_0} \in \mathbb{Z}^{Q_0}$ . Then we have reflections  $r_i$  defined as follows:  $r_i : \mathbb{Z}^{Q_0} \rightarrow \mathbb{Z}^{Q_0}$ ,  $r_i(\mathbf{d}) := (r_i(\mathbf{d})_j)_{j \in Q_0}$  with

$$r_i(\mathbf{d})_j = x_j \text{ for } j \neq i, \text{ and } r_i(\mathbf{d})_i = -x_i + \sum_{j \text{ adjacent } i} x_j.$$

Let  $W$  be the subgroup of  $\text{Aut}(\mathbb{Z}^{Q_0})$  generated by all the reflections  $r_i$ ,  $i \in Q_0$ . Let  $(-, -) : \mathbb{Z}^{Q_0} \times \mathbb{Z}^{Q_0} \rightarrow \mathbb{Z}$  be the symmetric bilinear form corresponding to the Tits form of  $Q$  and  $S_Q = \{\mathbf{e}_i, i \in Q_0\}$  be the set of simple roots for  $Q$ . Then we have the *fundamental region* associated with  $Q$ :

$$F_Q := \{\mathbf{d} \in \mathbb{N}_0^{Q_0} \setminus \{0\} \mid (\mathbf{d}, \mathbf{e}_i) \leq 0, \text{ for all } i \in Q_0 \text{ and } \mathbf{d} \text{ has connected support}\}$$

In [Ka1] Kac gave a description of the (positive) root system  $\Delta_+(Q)$  assigned to a quiver  $Q$  in combinatorial terms:  $\Delta_+(Q) = \Delta_+^{\text{re}}(Q) \cup \Delta_+^{\text{im}}(Q)$ , where  $\Delta_+^{\text{re}}(Q) = WS_Q \cap \mathbb{N}_0^{Q_0}$  and  $\Delta_+^{\text{im}}(Q) = WF_Q$ . Let  $\nu_{\mathbf{d}}$  denote the maximal number of parameters on which a family of indecomposable representations of  $Q$  (over an algebraically closed field) with dimension vector  $\mathbf{d}$  depends. We can now formulate Kac's Theorem (see [Ka2], Theorem 1.10):

**Theorem 1.1** (Kac, 1982). *Let  $\mathbf{d} \in \mathbb{N}_0^{Q_0}$  be a dimension vector of representations of a quiver  $Q$  without loops and  $k$  be an algebraically closed field. Then:*

- (i) *There is an indecomposable representation over  $k$  with dimension vector  $\mathbf{d}$  if and only if  $\mathbf{d} \in \Delta_+(Q)$ .*
- (ii) *If  $\mathbf{d} \in \Delta_+^{re}(Q)$ , there is a unique indecomposable representation over  $k$  with dimension vector  $\mathbf{d}$ .*
- (iii) *If  $\mathbf{d} \in \Delta_+^{im}(Q)$ , then  $\nu_{\mathbf{d}} = 1 - q(\mathbf{d})$ . Furthermore, there is a unique  $\nu_{\mathbf{d}}$ -parameter family of indecomposable representations with dimension vector  $\mathbf{d}$ .*

## 1.5 Reflections

Finally we recall some terminology of Bernstein, Gelfand, Ponomarev reflections. These reflections will be used in chapter 7 and 9, but also for doing the reflections in the universal covering of the 3-Kronecker quiver in chapter 8. Again let  $Q = (Q_0, Q_1)$  be a quiver without cycles and let  $(V_j, V_\alpha)_{j \in Q_0, \alpha \in Q_1}$  be a representation of  $Q$  and  $i$  be a sink<sup>3</sup>. Given any vertex  $i$ , the quiver  $\sigma_i Q$  is obtained from  $Q$  by reversing all arrows which start or end at  $i$ . An ordering  $i_1, \dots, i_n$  of the vertices of  $Q$  is called *admissable* if for each  $p$  the vertex  $i_p$  is a sink for  $\sigma_{i_{p-1}} \dots \sigma_{i_1} Q$ . In that case we have  $\sigma_{i_n} \dots \sigma_{i_1} Q = Q$ .

**Lemma 1.2.** *There exists an admissable ordering of the vertices of  $Q$  if and only if there is no oriented cycle in  $Q$ .*

*Proof.* We show one implication by induction on the number of vertices. So suppose  $Q$  has no oriented cycle and let  $i_n$  be the starting vertex of a path of maximal length. Then  $i_n$  is a source and we remove it from  $Q$ . There is an admissable ordering  $i_1, \dots, i_{n-1}$  of the remaining vertices and we get an admissable ordering  $i_1, \dots, i_n$  of the vertices of  $Q$ .  $\square$

Let  $n = |Q_0|$ . Recall the *Euler form*, which is the bilinear form

$$\begin{aligned} \langle -, - \rangle : \mathbb{Z}^n \times \mathbb{Z}^n &\rightarrow \mathbb{Z} \text{ with} \\ \langle x, y \rangle &= \sum_{i \in Q_0} x_i y_i - \sum_{\alpha \in Q_1} x_{s(\alpha)} y_{t(\alpha)}. \end{aligned}$$

We obtain on  $\mathbb{Z}^n$  a symmetric bilinear form by defining

$$(x, y) = \langle x, y \rangle + \langle y, x \rangle.$$

---

<sup>3</sup>We call a vertex  $j \in Q_0$  a *sink* if there are no arrows starting at  $j$ . Dually we can define a *source* to be a vertex with no arrows ending in it.

Suppose that  $Q$  has no loops, i.e. no arrows from a vertex to itself. The reflection with respect to a vertex  $i$  is by definition the map

$$\sigma_i : \mathbb{Z}^n \rightarrow \mathbb{Z}^n \text{ with } \sigma_i(x) = x - \frac{2(x, e_i)}{(e_i, e_i)} e_i,$$

where  $e_i$  is the  $i$ th coordinate vector. It is easily checked that the  $\sigma_i$  are automorphisms of order two preserving the bilinear form  $(-, -)$ . For the set  $\mathbb{Z}^n$  we use the partial order which is defined as  $x \leq y \iff x_i \leq y_i$  for all  $i$ .

Let  $i$  be a vertex of  $Q$ . We define a pair of reflection functors  $S_i^+$  and  $S_i^-$  and closely follow the introductory notes due to H. Krause [Kr2]: Fix representations  $X, X'$  of  $Q$  and a morphism  $\phi : X \rightarrow X'$ . Let us first take the case of vertex  $i$  being a sink of  $Q$ : If the vertex  $i$  is a sink of  $Q$ , then we construct

$$S_i^+ : \text{Rep}(Q, k) \rightarrow \text{Rep}(\sigma_i Q, k)$$

as follows: We define  $S_i^+ X = Y$  by letting  $Y_j = X_j$  for a vertex  $j \neq i$  and letting  $Y_i$  be the kernel of the map  $\eta = (X_\alpha)$  in the following sequence

$$0 \rightarrow Y_i \rightarrow \bigoplus_{\alpha \in Q_1, t(\alpha)=i} X_{s(\alpha)} \rightarrow X_i \rightarrow 0$$

where the first map, call it  $\eta'$ , is the inclusion map of the kernel. For an arrow  $\alpha$  in  $Q$ , let  $Y_\alpha = X_\alpha$  if  $t(\alpha) \neq i$ , and  $Y_\alpha : Y_i \rightarrow X_{s(\alpha)} = Y_{s(\alpha)}$  be the map  $\eta'$  followed by the canonical projection onto  $X_{s(\alpha)}$  if  $t(\alpha) = i$ . For the morphism  $S_i^+ \phi = \psi$  let  $\psi_j = \phi_j$  if  $j \neq i$  and let  $\psi_i : Y_i \rightarrow Y'_i$  be the restriction of the map

$$(\phi_{s(\alpha)}) : \bigoplus_{\alpha \in Q_1, t(\alpha)=i} X_{s(\alpha)} \rightarrow \bigoplus_{\alpha \in Q_1, t(\alpha)=i} X'_{s(\alpha)}.$$

Considering the other case, i.e. when  $i$  is a source of  $Q$ , we dually construct

$$S_i^- : \text{Rep}(Q, k) \rightarrow \text{Rep}(\sigma_i Q, k)$$

as follows: Define  $S_i^- X = Y$  by letting  $Y_j = X_j$  for a vertex  $j \neq i$ , and letting  $Y_i$  be the cokernel of the map  $\vartheta = (X_\alpha)$  in the short exact sequence

$$0 \rightarrow X_i \rightarrow \bigoplus_{\alpha \in Q_1, s(\alpha)=i} X_{t(\alpha)} \rightarrow Y_i \rightarrow 0$$

where  $\varphi'$  denotes the canonical map onto the cokernel. For an arrow  $\alpha$  in  $Q$ , let  $Y_\alpha = X_\alpha$  if  $s(\alpha) \neq i$ , and  $Y_\alpha : Y_{t(\alpha)} = X_{t(\alpha)} \rightarrow Y_i$  be the restriction of  $\varphi'$  to  $X_{t(\alpha)}$  if  $s(\alpha) = i$ . For the morphism  $S_i^- \phi = \psi$  let  $\psi_j = \phi_j$  if  $j \neq i$  and let  $\psi_i : Y_i \rightarrow Y'_i$  be the map which is induced by

$$(\phi_{t(\alpha)}) : \bigoplus_{\alpha \in Q_1, s(\alpha)=i} X_{t(\alpha)} \rightarrow \bigoplus_{\alpha \in Q_1, s(\alpha)=i} X'_{t(\alpha)}.$$

In the first case, when  $i$  is a sink of  $Q$ , we define a natural monomorphism

$$\iota_i X : S_i^- S_i^+ X \rightarrow X$$

by letting  $(\iota_i X)_j = \text{id}_{X_j}$  for a vertex  $j \neq i$ , and letting  $(\iota_i X)_i$  be the canonical map

$$(S_i^- S_i^+ X)_i = \text{Cok } \eta' \cong \text{Im } \eta \rightarrow X_i.$$

Similarly, when  $i$  is a source of  $Q$ , we define a natural epimorphism

$$\pi_i X : X \rightarrow S_i^+ S_i^- X$$

by letting  $(\pi_i X)_j = \text{id}_{X_j}$  for a vertex  $j \neq i$ , and letting  $(\pi_i X)_i$  be the canonical map

$$X_i \rightarrow \text{Im } \eta \cong \text{Ker } \eta' (S_i^+ S_i^- X)_i.$$

With above considerations we get the following lemma:

**Lemma 1.3.**  $S_i^+$  and  $S_i^-$  are functors, that is,  $S_i^+ \text{id } X = \text{id } S_i^+ X$  and  $S_i^- \text{id } X = \text{id } S_i^- X$  for every representation  $X$  and  $S_i^+(\psi\phi) = (S_i^+\psi)(S_i^+\phi)$  and  $S_i^-(\psi\phi) = (S_i^-\psi)(S_i^-\phi)$  for every pair  $\phi : X \rightarrow Y$  and  $\psi : Y \rightarrow Z$  of morphisms.

**Lemma 1.4.** Let  $X, X'$  be representations of  $Q$  and let  $i$  be a vertex of  $Q$ .

$$(i) \quad S_i^+(X \oplus X') = S_i^+ X \oplus S_i^+ X' \quad \text{and} \quad S_i^-(X \oplus X') = S_i^- X \oplus S_i^- X'.$$

$$(ii) \quad X = (S_i^- S_i^+ X) \oplus \text{Cok } \iota_i X \quad \text{and} \quad X = (S_i^+ S_i^- X) \oplus \text{Ker } \pi_i X.$$

$$(iii) \quad \text{If } \text{Cok } \iota_i X = 0, \text{ then } \mathbf{dim} S_i^+ X = \sigma_i(\mathbf{dim} X).$$

$$(iv) \quad \text{If } \text{Ker } \pi_i X = 0, \text{ then } \mathbf{dim} S_i^- X = \sigma_i(\mathbf{dim} X).$$

*Proof.* For (i) use that  $S_i^+$  resp.  $S_i^-$  is a functor satisfying  $S_i^+(\phi+\psi) = S_i^+\phi + S_i^+\psi$  resp.  $S_i^-(\phi+\psi) = S_i^-\phi + S_i^-\psi$  for any pair of parallel morphisms  $\phi, \psi$ .

(ii): The canonical map  $\rho'_i : X_i \rightarrow \text{Cok } \eta$  has a section  $\rho_i : \text{Cok } \eta \rightarrow X_i$ , that is,  $\rho'_i \rho_i = \text{id}_{\text{Cok } \eta}$ . This gives a morphism  $\rho : \text{Cok } \iota_i X \rightarrow X$  if we put  $\rho_j = 0$  for  $j \neq i$ . It is clear that  $\iota_i X : S_i^- S_i^+ X \rightarrow X$  and  $\rho : \text{Cok } \iota_i X \rightarrow X$  give a direct sum decomposition of  $X$ . Similarly for  $X = (S_i^+ S_i^- X) \oplus \text{Ker } \pi_i X$ . (iii) If  $\text{Cok } \iota_i X = 0$ , then we have

$$\mathbf{dim} Y_i = \sum_{\alpha \in Q_1, t(\alpha)=i} \mathbf{dim} X_s(\alpha) - \mathbf{dim} X_i,$$

and  $\mathbf{dim} Y_j = \mathbf{dim} X_j$  for  $j \neq i$ . Thus  $\mathbf{dim} Y = \sigma_i(\mathbf{dim} X)$ . Similarly for (iv).  $\square$

*Remark.* Note that the representations  $\text{Cok } \iota_i X$  and  $\text{Ker } \pi_i X$  are concentrated at the vertex  $i$ . Thus they are direct sums of copies of the simple representation  $S(i)$ .

**Corollary 1.5.** Let  $i$  be a sink and  $X$  an indecomposable representation of  $Q$ . Then the following are equivalent:

1.  $X \not\cong S(i)$ .
2.  $S_i^+ X$  is indecomposable.
3.  $S_i^+ X \neq 0$ .
4.  $S_i^- S_i^+ X \cong X$ .
5. The following map is an epimorphism:

$$(X_\alpha) : \bigoplus_{\alpha \in Q_1, t(\alpha)=i} X_s(\alpha) \rightarrow X_i.$$

6.  $\sigma_i(\mathbf{dim} X) > 0$ .
7.  $\mathbf{dim} S_i^+ X = \sigma_i(\mathbf{dim} X)$ .

The above corollary can also be stated for the case when vertex  $i$  is a source of  $Q$  and then using the functor  $S_i^-$ . We also get the following theorem as a consequence of above results:

**Theorem 1.6.** *The functors  $S_i^+$  and  $S_i^-$  induce mutually inverse bijections between the indecomposable representations of  $Q$  and the indecomposable representations of  $\sigma_i Q$ , with the exception of the simple representation  $S(i)$  corresponding to  $i$ , which is annihilated by these functors. Moreover,  $\mathbf{dim} S_i^+ X = \sigma_i(\mathbf{dim} X)$  for every indecomposable representation  $X$  not isomorphic to  $S(i)$ .*

## 1.6 Coxeter functors

Let  $Q$  be a quiver without oriented cycles and let  $i_1, \dots, i_n$  be an admissible ordering of the vertices of  $Q$ .

**Definition 1.2.** *The Coxeter functor with respect to this ordering is the functor*

$$C^+ = S_{i_n}^+ \dots S_{i_1}^+ : \text{Rep}(Q, k) \rightarrow \text{Rep}(Q, k).$$

We also define

$$C^- = S_{i_1}^- \dots S_{i_n}^- : \text{Rep}(Q, k) \rightarrow \text{Rep}(Q, k).$$

**Lemma 1.7.** *The functors  $C^+$  and  $C^-$  do not depend on the choice of the ordering of the vertices of  $Q$ .*

Now assume that  $Q_0 = \{1, \dots, n\}$  with  $1, \dots, n$  an admissible ordering. We then have:

**Lemma 1.8.** *Let  $i$  be a vertex.*

$$(i) \dim P(i) = \sigma_1 \dots \sigma_{i-1}(e_i) \text{ and } \dim I(i) = \sigma_n \dots \sigma_{i+1}(e_i).$$

$$(ii) P(i) \cong S_1^- \dots S_{i-1}^- S(i) \text{ and } I(i) \cong S_n^+ \dots S_{i+1}^+ S(i).$$

The Coxeter reflections are a very useful tool in representation theory and can be used to compute the Auslander-Reiten translate of a representation. This was also programmed using Maple for the 3-Kronecker quiver. A copy of the program can be found in Appendix A.

## 2 Tools & Visualization

### 2.1 Process of Simplification

In general, the aim of the *process of simplification*, introduced by Ringel in [Ri8], is to construct indecomposable objects in an abelian category  $\mathcal{C}$ . This is done using basic indecomposable objects and building larger ones: Given indecomposable objects  $X, Y$  in  $\mathcal{C}$ , look for non-split exact sequences  $0 \rightarrow X \rightarrow M \rightarrow Y \rightarrow 0$ , hoping that  $M$  is indecomposable too. If  $X, Y$  are simple, then  $M$  is indecomposable. If  $X, Y$  are not simple in  $\mathcal{C}$ , but belong to a full, exact, extension-closed subcategory  $\mathcal{F}$  of  $\mathcal{C}$ , such that  $X, Y$  are simple in  $\mathcal{F}$ , then again every non-split extension  $M$  is indecomposable (as object of  $\mathcal{F}$ , thus as object of  $\mathcal{C}$ ).

So given  $X, Y$  one needs to find  $\mathcal{F}$ , in which  $X, Y$  are simple (hence the name *process of simplification*). Necessary conditions for  $\mathcal{F}$  to exist:  $X, Y$  are *bricks*, i.e.  $\text{End}(X), \text{End}(Y)$  are fields (algebraically closed case), and  $X \cong Y$  or  $\text{Hom}(X, Y) = 0 = \text{Hom}(Y, X)$  ( $X, Y$  are then called *orthogonal*). These conditions are also sufficient for such a subcategory to exist.

In our particular case we take  $X = Y = R[1]$  as basic indecomposable object, which will be our *building block*, where  $\mathbf{dim} R[1] = (1, 1)$ , having  $\dim_k \text{End} R[1] = 1$  and  $\text{Ext}^1(R[1], R[1]) = 2$ . Then

$$\mathcal{F} = \mathcal{F}(R[1])$$

If  $M$  is an object of  $\mathcal{C}$ , then an  $R[1]$ -filtration of  $M$  is given by a sequence of subobjects

$$0 = M_0 \subseteq M_1 \subseteq M_2 \subseteq \dots \subseteq M_n = M,$$

with  $M_i/M_{i-1} \cong R[1]$ , for  $1 \leq i \leq n$ .

Then  $\mathcal{F}(R[1])$  is the full subcategory of all objects of  $\mathcal{C}$  with an  $R[1]$ -filtration, thus uniserial in  $\mathcal{F}(R[1])$ . By a theorem of Ringel (Theorem 1.2, [Ri8]),  $\mathcal{F}$  is an exact, extension-closed abelian subcategory of  $\mathcal{C}$ . In our case  $\mathcal{C}$  is the module category  $A\text{-mod}$ . Furthermore  $R[1]$  is simple in  $\mathcal{F}$ , and every object in  $\mathcal{F}$  has a  $R[1]$ -filtration. We will use this process of simplification to prove lemma 6.16 and lemma 4.1.

### 2.2 Coefficient quivers

Recall that a representation  $M$  over  $k$  of the 3-Kronecker quiver  $Q$  is of the form  $M = (M_x, M_\alpha)_{x, \alpha}$ : for every vertex  $x$  of the quiver, we have a finite-dimensional  $k$ -vector space  $M_x$  and for every arrow  $\alpha : x \rightarrow y$  we have a linear transformation  $M_\alpha : M_x \rightarrow M_y$ . A representation  $M$  of  $K(3)$  over  $k$  is an arbitrary module over the path algebra, which we denote by  $A$ .

Let us now introduce *coefficient quivers*<sup>4</sup>, a very useful tool in dealing with

---

<sup>4</sup>W. Crawley-Boevey has drawn attention to the use of coefficient quivers, see for example his lectures at the Banach center in Warsaw, 1988. See also [Ri1] from where above definition is taken.

representation of quivers. For this let  $d_x$  be the dimension of  $M_x$ . A basis  $\mathcal{B}$  of  $M$  is by definition a subset of the disjoint union of the various  $M_x$ , such that for any vertex  $x$  the set  $\mathcal{B}_x = \mathcal{B} \cap M_x$  is a basis for  $M_x$ . Assume such a basis  $\mathcal{B}$  of  $M$  is given. For any arrow  $\alpha : x \rightarrow y$  we may write  $M_\alpha$  as a  $(d_y \times d_x)$ -matrix  $M_{\alpha, \mathcal{B}}$ . Here the rows are indexed by  $\mathcal{B}_y$ , the columns are indexed by  $\mathcal{B}_x$ . Let  $M_{\alpha, \mathcal{B}}(b, b')$  be the corresponding matrix coefficients, where  $b \in \mathcal{B}_y$ ,  $b' \in \mathcal{B}_x$ . These  $M_{\alpha, \mathcal{B}}(b, b')$  are defined by  $M_\alpha(b) = \sum_{b' \in \mathcal{B}} M_{\alpha, \mathcal{B}}(b, b')b'$ .

**Definition 2.1.** *The coefficient quiver  $\Gamma(M, \mathcal{B})$  of  $M$  with respect to  $\mathcal{B}$  has the set  $\mathcal{B}$  as set of vertices and there is an arrow  $(\alpha, b, b')$  provided  $M_{\alpha, \mathcal{B}}(b, b') \neq 0$ .*

*Examples.* For the indecomposable injective  $A$ -module with dimension vector  $\mathbf{dim} M = \binom{3}{1}$  we have the following indecomposable representation:

$$\alpha = [1 \ 0 \ 0]; \beta = [0 \ 1 \ 0]; \gamma = [0 \ 0 \ 1]$$

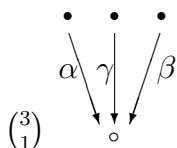

We have  $q(\mathbf{dim} M) = 1$ ,  $\dim \text{End}(M) = 1$ .

Next the indecomposable preinjective module with dimension vector  $\mathbf{dim} M = \binom{8}{3}$ :

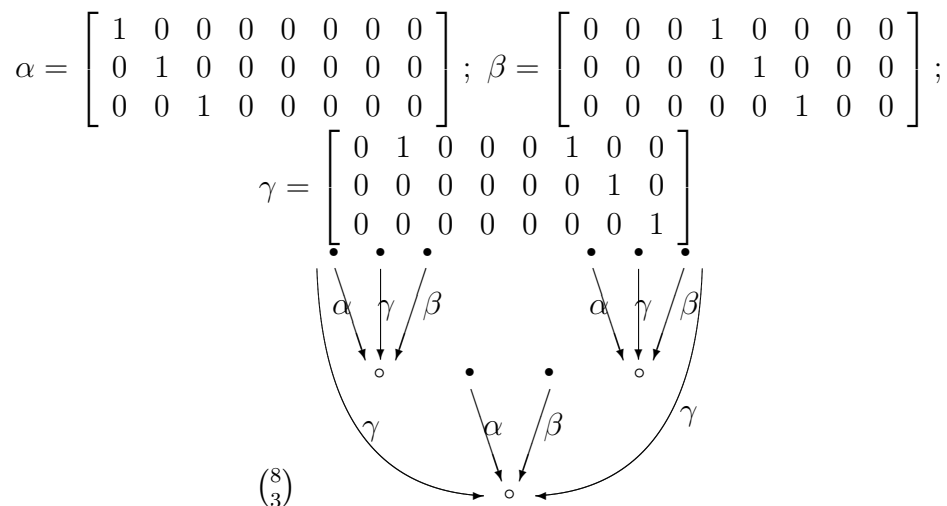

Here  $q(\mathbf{dim} M) = 1$ ,  $\dim \text{End}(M) = 1$ , since this is an indecomposable exceptional representation.

*Remark.* Note that coefficient quivers are not unique. Ringel has shown in [Ri1] that exceptional representations can be exhibited using matrices involving as coefficients just 0 and 1. Their coefficient quivers are trees, i.e., there are appropriate bases so that the coefficient quivers are trees. There is an interesting open problem concerning wild hereditary algebras: Let  $d$  be a positive root. Is

there an indecomposable tree module with dimension vector  $d$ ?<sup>5</sup> If  $d$  is imaginary, then there should be more than one isomorphism classes of indecomposable tree modules with dimension vector  $d$ .

## 2.3 Universal Covering

If  $M$  is an indecomposable representation, then any coefficient quiver for  $M$  has to be connected. The converse is not true in general, thus one cannot always see from the coefficient quiver, if the corresponding representation is indecomposable or not. In section 6 we will be working with representations defined as follows:

Let  $n \in \mathbb{N}_1$  and  $I$  a subset of  $\mathbb{N}_1$ . Define the representation  $R[n]_I$  for the quiver  $K(3)$  as follows: the vector space  $R[n]_I^{(1)}$  has basis  $z_i$ ,  $1 \leq i \leq n$ , the vector space  $R[n]_I^{(2)}$  has basis  $x_j, y_i$ , where  $1 \leq j \leq n$ , and  $1 \leq i \leq n$  with  $i \in I$ . Let

$$\alpha(x_j) = z_j, \beta(x_j) = z_{j-1}, \text{ and } \gamma(x_j) = 0,$$

$$\alpha(y_i) = 0, \beta(y_i) = 0, \text{ and } \gamma(y_i) = z_i,$$

for all  $1 \leq i, j \leq n$ ,  $i \in I$ , with  $z_0 = 0$ .

For example, here are two pictures of these representations as coefficient quivers. The first one is  $R[2]_I$ ,  $I = \{1\}$ , the second  $R[4]_I$ ,  $I = \{1, 3\}$  :

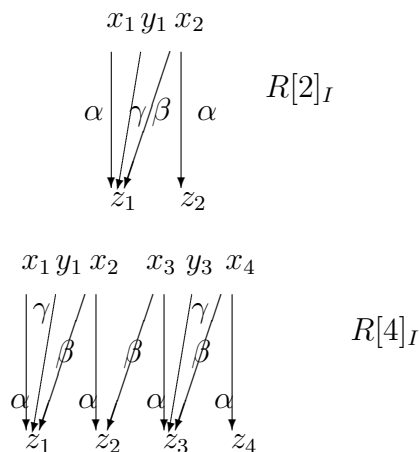

If  $I \cap \{1, \dots, n\} = \emptyset$ , then for any  $n \in \mathbb{N}_1$ ,  $R[n]_I$  equals its restriction to the maps  $\alpha, \beta$ . In this case  $R[n]_I$  can be viewed as a representation over the 2-Kronecker quiver, where  $R[n]_I$  restricted to  $\alpha, \beta$  is indecomposable. In general, let us show that the modules  $R[n]_I$  are indecomposable for every  $n \in \mathbb{N}_1$  and every set  $I \subseteq \mathbb{N}_1$ . This is done by using covering techniques. To do so we will make use of the 3-regular tree (3-regularity means that every vertex has precisely 3 neighbours). This has useful properties in connection with the 3-Kronecker quiver, since it is just the universal covering of the 3-Kronecker quiver.

<sup>5</sup>This question has been asked by C.M. Ringel at the International Conference on the Representation Theory of Algebras, Beijing, 2000.

Covering functors of  $k$ -algebras were introduced by P. Gabriel and by C. Riedtmann (see for example [G2]). The main idea is the following: If  $A$  is a  $k$ -algebra and if  $A' \rightarrow A$  is a covering functor with  $A'$  a  $k$ -algebra (or more generally a locally bounded  $k$ -category) then often the representation theory of  $A'$  is easier to handle than the one of  $A$ . For example, the Auslander-Reiten quiver of  $A'$ , considered as a topological space, is a covering of the one of  $A$ .

In general, if the quiver  $Q$  is considered as the universal covering (even Galois covering) of the quiver  $\bar{Q}$ , then any representation  $V$  of  $Q$  gives rise to a representation  $\bar{V}$  of  $\bar{Q}$  (by attaching to the vertex 0 of  $\bar{Q}$  the direct sum of the vector spaces attached to the various sinks of  $Q$ , and attaching to 1 the direct sum of the vector spaces attached to the sources). The representations of  $\bar{Q}$  obtained in this way are those which are gradable by the free (non-abelian) group in 3 free generators. The quivers which are of interest in our case are, on the one hand, the 3-Kronecker quiver  $\bar{Q}$  and, on the other hand, the bipartite quiver  $Q$  whose underlying graph (obtained by deleting the orientation of the arrows) is the 3-regular tree.<sup>6</sup> The covering functor  $V \mapsto \bar{V}$  preserves indecomposability and satisfies  $\mathbf{dim} \bar{V} = \mathbf{dim} V$ . Since in the case of  $R[n]_I$  each vector space attached to the sinks and sources is one-dimensional and the quiver  $Q$  is connected we get:

**Proposition 2.1.** *Let  $n \in \mathbb{N}_1$ ,  $I \subseteq \mathbb{N}_1$ . Then  $R[n]_I$  is indecomposable.*

Proposition 2.1 has also been proved in [CB2], theorem 1.4, where the special case of tree modules has been given particular consideration.

Let us prove the more general result in the following setting: Let  $F : A \rightarrow B$  be a Galois covering defined by the action of  $G$ . Let  $A - \text{Mod}$  be the category of left  $A$ -modules. Define functors:

$$F : B - \text{Mod} \rightarrow A - \text{Mod}, \quad (Y : B \rightarrow k - \text{Mod}) \mapsto (Y \circ F : A \rightarrow k - \text{Mod})$$

$$F_\lambda : A - \text{Mod} \rightarrow B - \text{Mod}, \quad (X : A \rightarrow k - \text{Mod}) \mapsto (F_\lambda X(a) \xrightarrow{F_\lambda X(f)} F_\lambda X(b)),$$

with  $F_\lambda X(a) = \bigoplus_{g \in G} X(gi) \ni (a_g)$ ,  $F_\lambda X(b) = \bigoplus_{g \in G} X(gj) \ni (\sum_h X(f_{h^{-1}g} a_h))_g$ , where  $(f_g) = f \in B(a, b) = \bigoplus_{g \in G} A(i, gj)$ . The latter will be called the *push-down* functor, the first *pull-up* functor. Observe that  $F_\lambda$  is a left adjoint to  $F$ . Recall that  $G$  acts on  $A - \text{Mod}$  and  $X \in A - \text{Mod}$  is  $G$ -stable if  $X^g = X$  for every  $g \in G$ . The category of  $G$ -stable  $A$ -modules is denoted by  $A - \text{Mod}^G$ .

Assume  $G$  acts freely on  $A$  and  $F : A \rightarrow B = A/G$  is the corresponding Galois covering. Let  $X \in A - \text{Mod}$ . The stabilizer  $G_X$  is the subgroup of  $G$  formed by those  $g \in G$  such that  $X^g \cong X$ . That is,  $X \in A - \text{Mod}^H$  if  $H \subset G_X$ .

**Proposition 2.2.**

(a) *For any  $X \in A - \text{Mod}$  and  $g \in G$ ,  $F_\lambda X^g \cong F_\lambda X$ . Moreover,  $F.F_\lambda X \xrightarrow{\sim} \bigoplus_{g \in G} X^g$  as  $A$ -modules.*

---

<sup>6</sup>In section 8 we have pictured several indecomposable representations over the universal covering.

(b) If  $X \in A - ind$  and  $G$  is torsion-free, then  $G_X = (1)$ .

(c) If  $X \in A - ind$  and  $G_X = (1)$ , then  $F_\lambda X$  is indecomposable and for any module  $Y \in A - mod$  with  $F_\lambda X \cong F_\lambda Y$ , then  $Y \cong X^g$  for some  $g \in G$ .

*Proof.* (a):  $F_\lambda X(a) = \bigoplus_{h \in G} X(hi) \xrightarrow{\sim} F_\lambda X^g(a) = \bigoplus_{h \in G} X(hgi)$  canonically. Hence  $F.F_\lambda X(i) = F_\lambda X(Fi) = \bigoplus_{h \in G} X(hi) = \bigoplus_{h \in G} X^h(i)$  and correspondingly in morphisms.

(b): Let  $g \in G_X$  for some  $X \in A - ind$ , then  $g$  establishes a permutation of  $suppX$  (a finite set). Then for some  $s \in \mathbb{N}_1$ ,  $1 = g^s$  on  $suppX$ . Since  $G$  acts freely on  $A$ , then  $g^s = 1$ . Since  $G$  is torsion-free,  $g = 1$  and  $G_X = (1)$ .

(c): Assume  $F_\lambda X \cong Z \oplus Z'$ , then  $\bigoplus_{g \in G} X^g = F.F_\lambda X \cong F.Z \oplus F.Z'$ . Assume  $X$  is a direct summand of  $F.Z \in A - Mod^G$ , then  $\bigoplus_{g \in G} X^g \subset F.Z$  and  $F.Z' = 0$ . Therefore  $F_\lambda X$  is indecomposable. If  $F_\lambda X \cong F_\lambda Y$ , then  $Y$  is indecomposable and  $Y \cong X^g$  for some  $g \in G$ .  $\square$

### 3 Gabriel-Roiter measure

In this section  $A$  denotes a finite-dimensional algebra.

#### 3.1 Radical & socle series

Recall the following definitions and results: Let  $M$  be an  $A$ -module. Then the *radical* of  $M$ , denoted by  $\text{rad}(M)$ , is the smallest submodule of  $M$  for which  $M/\text{rad}(M)$  is a semisimple module. If  $A$  itself is considered as a module over  $A$  then, equivalently,  $\text{rad}(A)$  is the largest nilpotent ideal of  $A$ , and for any module  $M$ ,  $\text{rad}(M) = \text{rad}(A)M$ . Since  $\text{rad}(M)$  is also an  $A$ -module,  $\text{rad}(M)$  has a radical. This is denoted by  $\text{rad}^2(M)$ . Let us define  $\text{rad}^n(M) = \text{rad}(\text{rad}^{n-1}(M))$ . In particular it follows from this that  $\text{rad}^n(M) = \text{rad}^n(A)M$ . We thus have the following series, known as the *radical series* of  $M$ :

$$M = \text{rad}^0(M) \supseteq \text{rad}^1(M) \supseteq \text{rad}^2(M) \supseteq \dots$$

If there is some  $r \in \mathbb{N}$  such that  $\text{rad}^r(M) = 0$  but  $\text{rad}^{r-1}(M) \neq 0$ , then we say that  $r$  is the *radical length* of  $M$  (if the algebra is finite-dimensional then such  $r$  will always exist). We call  $\text{rad}^{n-1}(M)/\text{rad}^n(M)$  the  $n^{\text{th}}$  *radical layer* of  $M$ , and we refer to the first radical layer as  $\text{top}(M)$ .

Let  $M$  be a finite-dimensional  $A$ -module. Then the *socle* of  $M$ , denoted by  $\text{soc}(M)$ , is the largest semisimple submodule of  $M$ . The quotient module  $M/\text{soc}(M)$  is also an  $A$ -module, so  $M/\text{soc}(M)$  also has a socle, and we let  $\text{soc}^2(M)$  be the submodule of  $M$  containing  $\text{soc}(M)$ , such that  $\text{soc}^2(M)/\text{soc}(M)$  is the socle of  $M/\text{soc}(M)$ . We recursively define  $\text{soc}^n(M)$  to be the submodule of  $M$  containing  $\text{soc}^{n-1}(M)$ , such that  $\text{soc}^n(M)/\text{soc}^{n-1}(M)$  is the socle of  $M/\text{soc}^{n-1}(M)$ .<sup>7</sup> We thus have the following series, known as the *socle series* of  $M$  (taking  $\text{soc}^0(M) = 0$ ):

$$0 = \text{soc}^0(M) \subseteq \text{soc}^1(M) \subseteq \text{soc}^2(M) \subseteq \dots$$

Let  $r \in \mathbb{N}$  be such that  $\text{soc}^r(M) = M$  but  $\text{soc}^{r-1}(M) \neq M$ , then we say that  $r$  is the *socle length* of  $M$ . We call  $\text{soc}^n(M)/\text{soc}^{n-1}(M)$  the  $n^{\text{th}}$  *socle layer* of  $M$ .

If a module  $M$  has a finite radical length, then this equals the socle length of  $M$ , and this value is known as the *Loewey length* of  $M$ . If  $l$  is the Loewey length of  $M$ , and for all  $n$  the  $(l+1-n)^{\text{th}}$  radical layer of  $M$  is isomorphic to the  $n^{\text{th}}$  socle layer, then we say that the module  $M$  is *stable*.

#### 3.2 Definitions & notations

For the definition of the Gabriel-Roiter measure (and its different ways of expressing it) we need to define an ordering on the set of all subsets  $\mathcal{P}$  of natural

---

<sup>7</sup>It is also possible to characterise  $\text{soc}^i(M)$  as the submodule of  $M$  which is annihilated by  $\text{rad}^i(M)$ .

numbers. Consider the following relation on  $\mathcal{P}$ : let  $I, J$  be subsets of the natural numbers with  $I \neq J$ . Then  $I < J$  provided the smallest element in the symmetric difference (i.e. in  $(I \setminus J) \cup (J \setminus I)$ ) belongs to  $J$ .

**Definition 3.1.** *Let  $M$  be an  $A$ -module. Let  $I(M)$  be the supremum (with the above total order) of the sets  $\{|M_1|, \dots, |M_t|\}$ , where  $M_1 \subset M_2 \subset \dots \subset M_t$  is a chain of indecomposable submodules of  $M$ . We call  $I(M)$  the Gabriel-Roiter measure of  $M$ .*

We call an inclusion  $N \subset M$  of indecomposable  $A$ -modules a *Gabriel-Roiter inclusion*, if  $I(M) = I(N) \cup \{|M|\}$ . Ringel has shown in [Ri3] that for a Gabriel-Roiter inclusion  $N \subset M$ , the module  $M/N$  is indecomposable.

**Definition 3.2.** *Let  $M$  be an  $A$ -module. If there exists a chain of submodules  $M_1 \subset M_2 \subset \dots \subseteq \bigcup_i M_i = M$ , such that  $I(M) = \{|M_i|, \text{ with } i \in I, \text{ where } I \text{ is countable or finite}\}$ , then this chain is called a Gabriel-Roiter filtration of  $M$ .*

There is another way to define the Gabriel-Roiter measure of a module of finite length, which was given by Ringel in [Ri4]. Here the Gabriel-Roiter measure, denoted by  $\mu$ , is defined by induction on the length of the module and will be a rational number instead of a set of numbers. This has the advantage that one sees immediately which Gabriel-Roiter measure is bigger or smaller, since the usual ordering of rational numbers is used. For the zero module  $0$  the Gabriel-Roiter measure is  $\mu(0) = 0$ . Given an indecomposable module  $M$  of length  $|M| > 0$  and assume by induction that  $\mu(M')$  is already defined for any proper submodule  $M' \subset M$ . Then set  $\mu(M) = \max \mu(M') + \frac{1}{2^{|M|}}$ , where the maximum is taken over all proper submodules  $M' \subset M$ .

There is the following relationship between  $\mu(M)$  and  $I(M)$ , linking the two definitions:

$$\mu(M) = \sum_{i \in I(M)} \frac{1}{2^i}.$$

Finally, we will denote by  $r$  the map sending  $I(M)$  to  $\mu(M)$ .

### 3.3 Basic properties

The following properties of the Gabriel-Roiter measure are taken from [Ri4] and [Ri3], where full proofs can be found.

- For any non-zero module  $M$ , there is an indecomposable submodule  $M' \subset M$  with  $\mu(M') = \mu(M)$ . Thus in the definition of the Gabriel-Roiter measure it suffices to consider only indecomposable proper submodules.
- For any module  $M$ , the Gabriel-Roiter measure  $\mu(M)$  is the supremum of  $\mu(M')$ , where  $M'$  is a finitely generated indecomposable submodule of  $M$ .

- Let  $M$  be a module and  $N \subset M$  a submodule. Then  $\mu(N) \leq \mu(M)$ . If  $M$  is indecomposable and  $N$  a proper submodule of  $M$ , then  $\mu(N) < \mu(M)$ .
- For  $A$ -modules  $M, M'$  we have  $\mu(M \oplus M') = \max(\mu(M), \mu(M'))$ .
- If  $M_1, \dots, M_t$  are (not necessarily finitely generated) indecomposable  $\Lambda$ -modules, then  $\mu(\bigoplus M_i) = \max \mu(M_i)$ .

An important theorem of C.M. Ringel is the following. This is crucial for the construction of indecomposable representations in chapters 4 and 6.

**Theorem 3.1.** *Any module  $M$  with a Gabriel-Roiter filtration is indecomposable.*

The proof can be found in [Ri3], theorem 1. When conjecturing the possible largest Gabriel-Roiter measure of the central part in chapter 7, we need the following structure theory on the Gabriel-Roiter measure, which was introduced in [Ri3]:

**Theorem 3.2.** *Let  $A$  be a finite-dimensional algebra of infinite representation type. Then there are Gabriel-Roiter measures  $I_t, I^t$  for  $A$  (with  $t \in \mathbb{N}_1$ ) such that*

$$I_1 < I_2 < I_3 < \dots < I^3 < I^2 < I^1$$

*and such that any other Gabriel-Roiter measure  $I$  for  $A$  satisfies  $I_t < I < I^t$  for all  $t \in \mathbb{N}_1$ . Moreover, all these Gabriel-Roiter measures  $I_t$  and  $I^t$  are of finite type, i.e. there are only finitely many indecomposable modules having these Gabriel-Roiter measures.*

The indecomposable modules corresponding to the measures  $I_t$  lie in the so-called *take-off part* of the module category  $\text{mod } A$ , and those corresponding to the measures  $I^t$  are said to form the *landing part* of  $\text{mod } A$ .

Finally let us recall two more known results:

- Let  $A$  be a finite-dimensional algebra of infinite representation type. There do exist modules which are not finitely generated and which have a Gabriel-Roiter filtration

$$M_1 \subset M_2 \subset \dots \subseteq \bigcup_i M_i = M$$

such that all the modules  $M_i$  belong to the take-off part.

- The modules in the landing part are preinjective.

*Remark.* Note that for an arbitrary finite-dimensional algebra there usually will exist preinjective indecomposable modules which do not belong to the landing part. For example, any simple module belongs to the take-off part having length 1. So although a simple injective module is preinjective, it lies in the take-off part and not in the landing part. There may be even infinitely many isomorphism classes of preinjective indecomposable modules which do not belong to the landing part.

### 3.4 Preprojective modules

Dimension vector of $M$	Gabriel-Roiter measure $I(M)$	Gabriel-Roiter filtration	Gabriel-Roiter measure $\mu(M) = r(I(M))$
(1,0)	{1}	(1,0)	$\frac{1}{2}$
(3,1)	{1,4}	(1,0) $\subset$ (3,1)	$\frac{9}{16} = \frac{1}{2} + \frac{1}{16}$
(8,3)	{1,4,11}	(1,0) $\subset$ (3,1) $\subset$ (8,3)	$\frac{1153}{2048} = \frac{1}{2} + \frac{1}{16} + \frac{1}{2048}$
(21,8)	{1,4,11,29}	(1,0) $\subset$ (3,1) $\subset$ (8,3) $\subset$ (21,8)	$\frac{1}{2} + \frac{1}{16} + \frac{1}{2048} + \frac{1}{2^{29}}$
$\vdots$			

Table 1: Gabriel-Roiter measures for indecomposable preprojective modules.

In the case of the 3-Kronecker quiver, let us quickly deal with the rather simple task of computing the Gabriel-Roiter measure of a preprojective module. One can read off the submodule chain from the preprojective component of the Auslander-Reiten quiver. Note that for any indecomposable preprojective module  $M$  over the 3-Kronecker quiver the Tits form is  $q(M)=1$ . Hence  $p=0$ , where  $p$  denotes the number of parameters in its representation. Also, since every indecomposable preprojective module is exceptional, any indecomposable preprojective module is uniquely determined by its dimension vector. In table 1 the first Gabriel-Roiter measures for indecomposable preprojective modules for the 3-Kronecker quiver are computed.

## 4 An infinite Gabriel-Roiter filtration from the 2-Kronecker quiver

The classical example of an infinite-dimensional module is the following: Let  $\Lambda$  be the Kronecker algebra, that is, the path algebra of the tame hereditary quiver with two vertices and two arrows in the same direction. Then  $Q := (k(X), k(X), \cdot id, \cdot X)$ , with  $k(X)$  being the field of rational functions in one variable, is the unique indecomposable torsion-free divisible module.

Recall that the totally ordered set of all the Gabriel-Roiter measures for the Kronecker quiver can be drawn as follows (see [Ri4]):

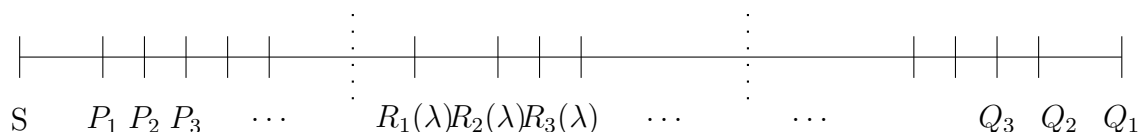

There are precisely two accumulation points, which are drawn as dotted vertical lines. They correspond to the only Gabriel-Roiter measures for infinitely generated modules. The first one to the left is the Gabriel-Roiter measure  $\{1, 3, 5, 7, \dots\}$  for all indecomposable torsion-free modules. The second one to the right is  $\{1, 2, 4, 6, 8, \dots\}$  corresponds to the Prüfer modules.

We will use an infinite Gabriel-Roiter filtration known from the 2-Kronecker quiver to construct an infinite Gabriel-Roiter filtration in the 3-Kronecker case. As before, the 3-Kronecker quiver,  $K(3)$ , will be the quiver with two vertices and three arrows:

$$K(3) : 1 \bullet \begin{array}{c} \xleftarrow{\alpha} \\ \xleftarrow{\beta} \\ \xleftarrow{\gamma} \end{array} \bullet 2$$

Let  $A$  be the path-algebra of the quiver  $K(3)$ , where  $k$  is an algebraically closed field. A representation of  $K(3)$  is of the form  $(V_1, V_2; \alpha, \beta, \gamma)$ , where  $V_1, V_2$  are vector spaces and  $\alpha, \beta, \gamma : V_2 \rightarrow V_1$  are three linear transformations.

### 4.1 Construction of $R[n]$

Let  $n \in \mathbb{N}_1$ . Define  $R[n]$  to be the following representation:  $R[n]^{(1)}$  is the vector space with basis  $z_i$ ,  $1 \leq i \leq n$ , and  $R[n]_1^{(2)}$  the vector space with basis  $x_j$ , where  $1 \leq j \leq n$ . Let

$$\alpha(x_j) = z_j, \beta(x_j) = z_{j-1}, \text{ and } \gamma(x_j) = 0,$$

for all  $j$  with  $z_0 = 0$ . Define  $R[0] = 0$ .

For example,  $R[1]$  is the representation of dimension vector  $(1, 1)$ , which we can write as coefficient quiver in the following way:

$$\begin{array}{ccc} \bullet x_1 & & \\ \downarrow \alpha & R[1] & \\ \circ z_1 & & \end{array}$$

$R[2]$  is the following representation of dimension vector  $(2, 2)$ :

$$\begin{array}{ccc}
 \bullet x_1 & \bullet x_2 & \\
 \downarrow \alpha & \swarrow \beta & \downarrow \alpha \\
 \circ z_1 & \circ z_2 & 
 \end{array}
 \quad R[2]$$

Then  $R[n]$  has dimension vector  $(n, n)$ . For every  $n \in \mathbb{N}_1$  this is an indecomposable representation over  $K(3)$ , since  $\gamma$  acts via 0 and we can view this representation as a  $K(2)$ -representation of dimension vector  $(n, n)$ .

Now we will look at the infinite-dimensional representation  $R[\infty]$ , which is defined to be the following representation:  $R[\infty]^{(1)}$  is the vector space with basis  $z_i$ ,  $i = 1, 2, \dots$ , and  $R[\infty]^{(2)}$  the vector space with basis  $x_j$ , where  $j \geq 1$ . Let

$$\alpha(x_j) = z_j, \beta(x_j) = z_{j-1}, \text{ and } \gamma(x_j) = 0,$$

for all  $j$  with  $z_0 = 0$ .

Picturing this as a coefficient quiver:

$$\begin{array}{ccccccccccc}
 \bullet x_1 & \bullet x_2 & \bullet x_3 & \bullet x_4 & \bullet x_5 & \bullet x_6 & \bullet x_7 & \dots & & & \\
 \downarrow \alpha & \swarrow \beta & \downarrow \alpha & \swarrow \beta & \downarrow \alpha & \swarrow \beta & \downarrow \alpha & \swarrow \beta & \downarrow \alpha & \swarrow \beta & \dots \\
 \circ z_1 & \circ z_2 & \circ z_3 & \circ z_4 & \circ z_5 & \circ z_6 & \circ z_7 & \dots & & & 
 \end{array}
 \quad R[\infty]$$

**Lemma 4.1.**  $R[\infty]$  has unique Gabriel-Roiter filtration

$$\text{soc } R[1] \subset R[1] \subset R[2] \subset \dots$$

## 4.2 Proof of Lemma 4.1

For the proof we will use the process of simplification as described in 2.1. Recall that over the Kronecker quiver  $K(2)$ , indecomposable representations of dimension vector  $(n, n)$  are regular and appear in homogeneous tubes. By [Ri3] we have that regular modules  $R_\lambda[n]$ , for  $\lambda \in \mathbb{P}^1(k)$ ,  $n \in \mathbb{N}_1$  and with  $\dim R_\lambda[n] = (n, n)$ , have Gabriel-Roiter measure  $\{1, 2, 4, 6, \dots, 2n\}$ . The Gabriel-Roiter measure for the Prüfer modules (which are infinitely generated) is  $\{1, 2, 4, 6, 8, \dots\}$ .

*Proof of Lemma 4.1.* This will be done by induction using the knowledge of the infinite Gabriel-Roiter filtration of the Kronecker quiver.

Consider the category  $\mathcal{F} = \mathcal{F}(R[1])$  (the full subcategory of all representations with an  $R[1]$ -filtration). The indecomposable object  $R[1]$  is simple in  $\mathcal{F}$ . If we restrict to the Kronecker case, then this object lies in a homogenous tube and

is *quasi-simple* (i.e. it sits at the mouth of the tube<sup>8</sup>) in the category of regular representations. As before, for all  $n \in \mathbb{N}_1$ , we can view the representations  $R[n]$  as  $K(2)$ -representations. This is also true for  $R[\infty]$ . We want to show that  $R[\infty]$  has as unique Gabriel-Roiter filtration  $\text{soc } R[1] \subset R[1] \subset R[2] \subset \dots$ : The socle of  $R[1]$ ,  $\text{soc } R[1]$ , is one-dimensional and isomorphic to the simple module  $S_1$  of dimension vector  $\mathbf{dim } S_1 = (1, 0)$  having Gabriel-Roiter measure  $\{1\}$ . By the process of simplification (see section 2.1 and [Ri8]),  $R[\infty]$  is uniserial in  $\mathcal{F}$ . The module  $R[1]$  is the unique submodule of  $R[\infty]$  having Gabriel-Roiter measure  $\{1, 2\}$ . Viewed as a representation over the Kronecker quiver, this is the module sitting at the mouth of the homogenous tube, which has Gabriel-Roiter measure  $\{1, 2\}$ . Note, that there is no submodule of  $R[\infty]$  having Gabriel-Roiter measure  $\{1, 2, 3\}$ , since it would have dimension vector  $(2, 1)$ , and such a module is injective over the Kronecker quiver, so cannot be a submodule in the filtration of regular modules. Similarly, we have no submodule of  $R[\infty]$  having Gabriel-Roiter measure  $\{1, 2, 4, 5\}$ , since such a module would be preinjective over the Kronecker quiver, where the Gabriel-Roiter measures of the preinjective modules  $Q_n$ ,  $n \in \mathbb{N}_0$ , with  $\mathbf{dim } Q_n = (n, n + 1)$  are given by  $\{1, 2, 4, 6, \dots, 2n, 2n + 1\}$ , as shown in [Ri3]. For any  $n \in \mathbb{N}_1$ ,  $R[n]$  is uniserial in  $\mathcal{F}$  with composition length  $2n$  in mod  $A$ . (In the homogenous tube over  $K(2)$  it is sitting at quasi-length  $n$ ). So  $R[n]$  is the unique submodule of  $R[\infty]$  having Gabriel-Roiter measure  $\{1, 2, 4, 6, \dots, 2n\}$ , with Gabriel-Roiter filtration  $\text{soc } R[1] \subset R[1] \subset R[2] \subset \dots$ . This completes the proof of lemma 4.1.  $\square$

---

<sup>8</sup>An indecomposable  $A$ -module  $M$ , which lies in the regular component of the Auslander-Reiten quiver, is called *quasi-simple*, if the Auslander-Reiten sequence  $0 \rightarrow \tau M \rightarrow E \rightarrow M \rightarrow 0$  has indecomposable middle term  $E$ . See definition 9.1.

## 5 Uniserial and piling modules

### 5.1 Uniserial modules

**Definition 5.1.** *An  $A$ -module  $M$  over a finite-dimensional algebra is said to be uniserial if it has a unique composition series.*

$M$  is uniserial if and only if its submodule lattice is a chain. If  $M$  is uniserial, then so is every submodule of  $M$ , and every quotient of  $M$ . Furthermore, because a uniserial module  $M$  necessarily has a simple top (and a simple socle), it must be indecomposable.

### 5.2 Piling submodules

**Definition 5.2.** *A submodule  $W$  of a module  $M$  is a piling submodule, provided either  $W = 0$  or  $W$  is indecomposable and the Gabriel-Roiter measure of  $M$  starts with that of  $W$ , i.e.  $\mu(W) = \mu(M) \cap \{1, 2, \dots, |W|\}$ .*

Piling submodules have the following nice properties, which are easily verified:

- The zero submodule of a module  $M$  is always a piling submodule, as is any submodule of  $M$  of length 1.
- Any submodule with simple socle of a module  $M$  is a piling submodule.
- Piling submodules of  $M$  of the same length have the same Gabriel-Roiter measure.
- If  $W$  is a piling submodule of  $M$ , then all submodules of  $W$  occurring in a Gabriel-Roiter filtration of  $W$  are piling submodules of  $M$ .

**Proposition 5.1.**

1. *If  $W$  is a piling submodule of  $M$  and there is an indecomposable module  $W'$  with  $W \subset W' \subseteq M$ , such that  $|W'| = |W| + 1$ , then  $W'$  is a piling submodule of  $M$ .*
2. *Let  $W$  be a piling submodule of  $M$  and  $W'$  an indecomposable module, such that  $W \subset W' \subseteq M$  and  $|W'| = |W| + 2$ . Assume further that if  $X$  is a piling submodule of  $M$  with  $|X| = |W|$ , then there is no indecomposable submodule  $X'$  with  $X \subset X'$  and  $|X'| = |X| + 1$ . Then  $W'$  is a piling submodule of  $M$ .*

*Proof.* The first result just follows from the definition of the Gabriel-Roiter measure: since  $W \subset W'$  and  $|W'| = |W| + 1$ ,  $W$  is a Gabriel-Roiter submodule of  $W'$ , so  $\mu(W') = \mu(W) \cup \{|W| + 1\}$ . Also  $W' \subseteq M$  and since  $W$  is piling,  $\mu(W') = (\mu(M) \cap \{1, 2, \dots, |W|\}) \cup \{|W| + 1\} = (\mu(M) \cup \{|W| + 1\}) \cap (\{1, 2, \dots, |W|\} \cup \{|W| + 1\}) = \mu(M) \cap \{1, 2, \dots, |W|, |W| + 1\}$ , so  $W'$  is piling too.

For the proof of the second statement proceed by contradiction. Since  $W$  is piling,  $\mu(W) = \mu(M) \cap \{1, \dots, |W|\}$ . Let  $\mu(M) = \{l_1, l_2, \dots, l_i, \dots, l_r\}$ , where  $l_1 < l_2 < \dots < l_i < \dots < l_r$  and  $l_i = |W|$ . Then  $\mu(W) = \{l_1, \dots, l_i\}$ . Now assume  $l_{i+1} = l_i + 1$ . There exists a chain of indecomposable modules  $X_1 \subset X_2 \subset \dots \subset X_{i+1}$  with  $|X_j| = l_j$ ,  $1 \leq j \leq i + 1$ . So  $X = X_i$  is piling,  $|X| = l_i = |W|$  and  $X' = X_{i+1}$  is indecomposable with  $|X'| = |X| + 1$ . This, however, contradicts the assumption that there is no indecomposable  $X'$  with  $X \subset X'$  and  $|X'| = |X| + 1$ . Therefore we must have  $l_{i+1} \geq l_i + 2$ . Since we have an indecomposable module  $W'$ , such that  $W \subset W' \subseteq M$  and  $|W'| = |W| + 2 = l_i + 2$ , we have  $l_{i+1} = l_i + 2 = |W'|$ . Thus  $\mu(W') = \mu(W) \cup \{|W'|\} = \{l_1, \dots, l_i, l_{i+1}\} = \mu(M) \cap \{1, \dots, |W'|\}$ , since  $W$  is piling. So  $W'$  is piling too.  $\square$

Let us finally give a name to a class of unique piling submodules.

**Definition 5.3.** *An indecomposable submodule  $U$  of a module  $M$  is called a knotted module, provided  $U$  is the unique piling submodule of  $M$  of length  $|U|$ .*

## 6 Construction of uncountably many Gabriel-Roiter measures

Our aim is to describe an algorithm to construct uncountably many Gabriel-Roiter measures for the 3-Kronecker quiver, where we let  $A$  denote its path algebra, i.e.  $A = kK(3)$ .

Let  $n \in \mathbb{N}_1$  and  $I$  a subset of  $\mathbb{N}_1$ . Define the representation  $R[n]_I$  for the quiver  $K(3)$  as follows: the vector space  $R[n]_I^{(1)}$  has basis  $z_i$ ,  $1 \leq i \leq n$ , the vector space  $R[n]_I^{(2)}$  has basis  $x_j, y_i$ , where  $1 \leq j \leq n$ , and  $1 \leq i \leq n$  with  $i \in I$ . Let

$$\alpha(x_j) = z_j, \beta(x_j) = z_{j-1}, \text{ and } \gamma(x_j) = 0,$$

$$\alpha(y_i) = 0, \beta(y_i) = 0, \text{ and } \gamma(y_i) = z_i,$$

for all  $1 \leq i, j \leq n$ ,  $i \in I$ , with  $z_0 = 0$ . Then  $R[n]_I$  only depends on  $I \cap \{1, 2, \dots, n\}$  and not on  $I$  itself, and we have inclusion maps  $R[0]_I \subset R[1]_I \subset R[2]_I \subset \dots \subset R[n]_I \subset \dots$ , where we define  $R[0]_I = 0$ .

Our aim is to prove the following theorem, classifying all piling submodules of  $R[n]_I$  of length at least 3 in the case  $1 \in I$ .

**Theorem 6.1.** *Let  $n \in \mathbb{N}_1$  and let  $I \subset \mathbb{N}_1$  with  $1 \in I$ . Then the piling submodules of  $R[n]_I$  are as follows:*

- (1) *For any  $1 \leq m \leq n$ ,  $R[m]_I$  is the unique piling submodule of length  $|R[m]_I|$ .*
- (2) *For any  $1 \leq m \leq n$  with  $m+1 \in I$ , and for every  $\mu \in k$ ,  $R[m]_I + A(x_{m+1} + \mu y_{m+1})$  is a piling submodule of length  $|R[m+1]_I| - 1$ .*
- (3) *There are no other piling submodules of  $R[n]_I$  of length at least 3.*

*Remarks.*

1. Note that  $|R[m]_I| = 2m + |I \cap \{1, 2, \dots, m\}|$  is a number depending only on  $m$  and  $I \cap \{1, 2, \dots, m\}$ . Thus the theorem states in particular the existence of piling submodules of certain lengths.
2. In the case  $1 \in I$ , the modules in (2) form a one-parameter family of piling submodules of  $R[m+1]_I$ , which are maximal in  $R[m+1]_I$  and contain  $R[m]_I$ . These piling submodules form an affine line.
3. The simple modules are the only piling submodules of length 1.
4. The piling submodules of length 2 are classified in proposition 6.4.

**Corollary 6.2.** *Let  $n \in \mathbb{N}_1$  and  $I \subset \mathbb{N}_1$  with  $1 \in I$ . Then any piling submodule of  $R[n]_I$  of length at least 3 belongs to a Gabriel-Roiter filtration of  $R[n]_I$ .*

*Remarks.*

1. There is only one submodule of length 1 occurring in any Gabriel-Roiter filtration of  $R[n]_I$ , namely  $\text{soc } R[1]_I$ .
2. The modules of length 2 occurring in a Gabriel-Roiter filtration of  $R[n]_I$ ,  $1 \in I$ , are as follows: There is a one-parameter family of the form  $A(x_1 + \mu y_1)$ , with  $\mu \in k$ . In addition we have a submodule of length 2 generated by  $\langle y_1 \rangle$ . Thus these piling submodules form a projective line.
3. By theorem 6.1 we know that  $R[1]_I$ , when  $1 \in I$ , is the only piling submodule of  $R[n]_I$  of length 3. By above remark we know all Gabriel-Roiter submodules and  $\mu(R[1]_I) = \{1, 2, 3\}$ . Therefore any Gabriel-Roiter measure of  $R[n]_I$  starts with  $\mu(R[1]_I)$ .
4. Since  $R[m]_I$  is the unique piling submodule of  $R[n]_I$ , for  $m \leq n$ ,  $1 \in I$ ,  $R[m]_I$  occurs in every Gabriel-Roiter filtration of  $R[n]_I$ .

The proofs of above theorem and its corollary will be given in section 6.3. First we need the results from the following two sections.

## 6.1 General Structure Lemma

For  $0 \leq m \leq n$  let us construct a map  $f : R[n]_I \rightarrow R[m]_I$ , such that  $\text{Ker}(f)$  is  $R[n-m]_J$ , where the set  $J = \{i-m \mid i \in I, i > m\}$ . We get the following isomorphism:

**Lemma 6.3.** *Let  $n \in \mathbb{N}_1$ , and  $I \subset \mathbb{N}_1$ . Then  $R[n]_I/R[m]_I \cong R[n-m]_J$ ,  $0 \leq m \leq n$ , and  $J = \{i-m \mid i \in I, i > m\}$ .*

*Proof.* For the proof we make the following convention for the notation of the basis: for  $i \leq 0$ ,  $x_i = 0$ ,  $y_i = 0$ , and  $z_i = 0$ , where  $R[n]_I^{(1)}$  has basis  $z_i$ ,  $1 \leq i \leq n$ , and  $R[n]_I^{(2)}$  has basis  $x_j, y_i$ , where  $1 \leq j, i \leq n$ , and  $i \in I$ . Then  $f : R[n]_I \rightarrow R[n-m]_I$  will be defined on each vector space as follows:

$$f^{(2)}(x_j) = x_{j-m}, \quad f^{(2)}(y_i) = y_{i-m} \text{ in case } i \in I, \text{ and } f^{(1)}(z_i) = z_{i-m}.$$

Let us check that  $f$  is a homomorphism. We need to show:

1.  $f^{(1)}\alpha = \alpha f^{(2)}$
2.  $f^{(1)}\beta = \beta f^{(2)}$
3.  $f^{(1)}\gamma = \gamma f^{(2)}$ ,

where  $\alpha(x_j) = z_j, \beta(x_j) = z_{j-1}, \gamma(x_j) = 0$ , and  $\alpha(y_i) = 0, \beta(y_i) = 0, \gamma(y_i) = z_i$ , for all  $1 \leq i, j \leq n, i \in I$ . Evaluating gives:

1.  $f^{(1)}\alpha(x_j) = f^{(1)}z_j = z_{j-m}$   
and  $\alpha f^{(2)}(x_j) = \alpha(x_{j-m}) = z_{j-m}$ , which are equal.  
Also for  $i \in I$ :  $f^{(1)}\alpha(y_i) = f^{(1)}0 = 0$   
and  $\alpha f^{(2)}(y_i) = \alpha(y_{i-m}) = 0$ , equal.
2.  $f^{(1)}\beta(x_j) = f^{(1)}z_{j-1} = z_{j-1-m}$   
and  $\beta f^{(2)}(x_j) = \beta(x_{j-m}) = z_{j-m-1}$ , which are equal.  
Also for  $i \in I$ :  $f^{(1)}\beta(y_i) = f^{(1)}0 = 0$   
and  $\beta f^{(2)}(y_i) = \beta(y_{i-m}) = 0$ , equal.
3.  $f^{(1)}\gamma(x_j) = f^{(1)}0 = 0$   
and  $\gamma f^{(2)}(x_j) = \gamma(x_{j-m}) = 0$ , which are equal.  
Also for  $i \in I$ :  $f^{(1)}\gamma(y_i) = f^{(1)}z_i = z_{i-m}$   
and  $\gamma f^{(2)}(y_i) = \gamma(y_{i-m}) = z_{i-m}$ , equal as needed.

□

## 6.2 Simple socle submodules of $R[n]_I$

For the proof of theorem 6.1 in section 6.3 we need to look at submodules of  $R[n]_I$  of length  $\leq 3$  with simple socle.

**Proposition 6.4.** *Let  $n \in \mathbb{N}_1$  and  $I$  a subset of  $\mathbb{N}_1$ . Then  $R[n]_I$  has precisely the following submodules  $N$  with simple socle of length 1, 2 or 3 :*

1.  $|N| = 1$ . *All the simple submodules of  $R[n]_I$  are such submodules, namely any non-trivial linear combination of the  $z_i, 1 \leq i \leq n$  generates such a submodule, so  $N = \langle \sum_{i=1}^n \lambda_i z_i \rangle, \lambda_i \in k, 1 \leq i \leq n$ , not all  $\lambda_i = 0$ .*
2.  $|N| = 2$ . *There are two types of such submodules:*
  - (a)  $N = Aw$ , where  $w = \sum_{i=1, i \in I}^n \mu_i y_i, \mu_i \in k$  for  $1 \leq i \leq n$ , with  $i \in I$  and not all  $\mu_i = 0$ .
  - (b)  $N = Aw$ . If  $1 \in I$ , take  $w = x_1 + \mu y_1, \mu \in k$ . If  $1 \notin I$ , take  $w = x_1$ .
3. *If  $1 \in I$ , then there exists a unique submodule  $N$  of length  $|N| = 3$  with simple socle, namely  $N = R[1]_I$ . If  $1 \notin I$ , then there is no such submodule.*

*Proof.* For the first part, the case of length 1 submodules, we look at the simple submodules of  $R[n]_I$ . Note that  $R[n]_I$  cannot have a simple injective submodule, thus  $N = \sum_{i=1}^n \lambda_i z_i, \lambda_i \in k, 1 \leq i \leq n$ , not all  $\lambda_i = 0$ , which is isomorphic to the simple projective module.

To show part 2 we proceed as follows. For indecomposable submodules  $N$  of length 2 with  $N \subset R[n]_I$  we are looking at a generator  $w$  of the top of  $N$  with a 1-dimensional image under  $\alpha, \beta, \gamma$ , where

$$w = \sum_{j=1}^n \lambda_j x_j + \sum_{i=1, i \in I}^n \mu_i y_i,$$

with  $\lambda_j, \mu_i \in k$ , for  $1 \leq i, j \leq n$ ,  $i \in I$ . Applying  $\alpha, \beta, \gamma$ , we get:

$$\alpha(w) = \sum_{j=1}^n \lambda_j \alpha(x_j) + \sum_{i=1, i \in I}^n \mu_i \alpha(y_i) = \sum_{j=1}^n \lambda_j z_j,$$

since  $\alpha(x_j) = z_j$  and  $\beta(y_i) = 0$ , whenever  $i \in I$ . Similarly we have

$$\beta(w) = \sum_{j=2}^n \lambda_j \beta(x_j) + \sum_{i=1, i \in I}^n \mu_i \beta(y_i) = \sum_{j=2}^n \lambda_j z_{j-1},$$

and

$$\gamma(w) = \sum_{i=1, i \in I}^n \mu_i \gamma(y_i) = \sum_{i=1, i \in I}^n \mu_i z_i.$$

Since we are looking for the submodules of length 2 we want this image  $\langle \alpha(w), \beta(w), \gamma(w) \rangle$  to be 1-dimensional. This is the case when the associated matrix

$$R = \begin{pmatrix} \lambda_1 & \lambda_2 & \dots & \dots & \lambda_n \\ \lambda_2 & \lambda_3 & \dots & \lambda_n & 0 \\ \mu_1 & \mu_2 & \dots & \dots & \mu_n \end{pmatrix}$$

has rank 1, where we define  $\mu_i = 0$ , for  $1 \leq i \leq n$  and  $i \notin I$ . This can only happen in the following two cases, giving the possibilities for  $N \subset R[n]_I$  with simple socle of length 2:

- (a) If for all  $j = 1, \dots, n$ ,  $\lambda_j = 0$ , and there exists at least one  $i$ , such that  $\mu_i \neq 0$ . Then  $w = \sum_{i=1, i \in I}^n \mu_i y_i$ , not all  $\mu_i = 0$ .
- (b) If  $\lambda_j \neq 0$  for at least one  $j$ , then  $j = 1$ , since otherwise we can choose the maximal  $j$ , such that  $\lambda_j \neq 0$ . But for  $j > 1$  we get  $rk(R) > 1$ , contradicting the fact that we need the rank to be 1 to get a 1-dimensional image. Therefore  $j = 1$ .

With  $\lambda_1 \neq 0$  and if  $1 \in I$ , we can have  $\mu_1$  to be zero or non-zero, but  $\mu_i = 0$  for all  $i \in I \cap \{2, \dots, n\}$ : If not, i.e.  $\mu_i \neq 0$  for at least one  $i > 1$ ,  $i \in I$ , then we would also have  $rk(R) > 1$ , a contradiction. In this second case we therefore have  $w = \lambda_1 x_1 + \mu_1 y_1$  with  $\mu_1$  possibly zero, and  $\alpha(w) = \lambda_1 z_1$ ,  $\beta(w) = 0$ ,  $\gamma(w) = \mu_1 z_1$  or zero. W.l.o.g. we have  $w = x_1 + \mu y_1$  for  $\mu \in k$ . In the case when  $1 \notin I$ , then  $w = x_1$ .

Note that every type (b) submodule is a submodule of  $R[1]_I$ . We will make use of the two types of submodules of length 2 for the proof of part 3 of the proposition. We need the following results:

**Lemma 6.5.** *Let  $N$  and  $N'$  be type (a) submodules of  $R[n]_I$  with  $N \cap N' \neq 0$ . Then  $N = N'$ .*

*Proof.* Since  $N$  and  $N'$  are of type (a), they are of length 2, have simple socle, and can be written as  $N = Aw$ , where  $w = \sum_{i=1, i \in I}^n \mu_i y_i$ ,  $\mu_i \in k$  for  $1 \leq i \leq n$ , with  $i \in I$  and not all  $\mu_i = 0$ . Similarly  $N' = Aw'$ , where  $w' = \sum_{i=1, i \in I}^n \mu'_i y_i$ ,  $\mu'_i \in k$  for  $1 \leq i \leq n$ , with  $i \in I$  and not all  $\mu'_i = 0$ . We have  $\gamma(w) = \sum_{i=1, i \in I}^n \mu_i z_i$ , and not all  $\mu_i = 0$ . But  $N \cap N' \neq 0$ , so  $\gamma(w)$  is a scalar multiple of  $\gamma(w')$  and therefore  $N = N'$ .  $\square$

**Lemma 6.6.** *Let  $N_1$  be a type (a) and  $N_2$  a type (b) submodule of  $R[n]_I$  with  $N_1 \cap N_2 \neq 0$ . Then  $1 \in I$  and  $N_1 + N_2 = R[1]_I$ .*

*Proof.* Both  $N_1$  and  $N_2$  are of length 2 with simple socle. Since  $N_1$  is of type (a), it can be written as  $N_1 = Aw$ , where  $w = \sum_{i=1, i \in I}^n \mu_i y_i$ ,  $\mu_i \in k$  for  $1 \leq i \leq n$ , with  $i \in I$  and not all  $\mu_i = 0$ .

Since  $N_1 \cap N_2 \neq 0$ , and  $N_2$  is of type (b), so can be written as  $N_2 = Aw'$ , where  $w' = x_1 + \mu' y_1$ , for  $\mu' \in k$ , we have  $1 \in I$ : If not, i.e. assume  $1 \notin I$ , so  $w' = x_1$ , then  $\alpha(w') = \alpha(x_1) = z_1$ ,  $\beta(w') = 0$ ,  $\gamma(w') = 0$ . This contradicts  $N_1 \cap N_2 \neq 0$ , since if  $1 \notin I$ , then  $z_1 \notin N_1$ . So  $1 \in I$ ,  $N_2 = A(x_1 + \mu' y_1)$  and since  $|N_1| = 2$  and  $N_1 \cap N_2 \neq 0$ , we have  $N_1 = Aw = A(\mu_1 y_1)$ . Now  $N_1 + N_2 = Aw + Aw' = A(x_1 + \mu' y_1) + A(\mu_1 y_1)$ . So  $N_1 + N_2$  has basis  $x_1, y_1, z_1$ , and  $N_1 + N_2 = R[1]_I$ .  $\square$

**Lemma 6.7.** *Let  $N$  and  $N'$  be type (b) submodules of  $R[n]_I$  with  $N \neq N'$  and  $N \cap N' \neq 0$ . Then  $1 \in I$  and  $N_1 + N_2 = R[1]_I$ .*

*Proof.* Since  $N$  and  $N'$  are of type (b), they are of length 2 and have simple socle. Furthermore, since  $N \neq N'$ , they cannot both be equal to  $A(x_1)$ . So we must have  $1 \in I$ . W.l.o.g. we can write  $N = Aw$ , where  $w = x_1 + \mu y_1$  for  $\mu \in k$  and  $N' = Aw'$ , where  $w' = x_1 + \mu' y_1$  for  $\mu' \in k$  and  $\mu' \neq \mu$ , since  $N \neq N'$ . With  $\alpha(w) = z_1$ , we have that  $N + N' = Aw + Aw'$  has basis  $x_1, y_1, z_1$ , thus  $N_1 + N_2 = R[1]_I$ .  $\square$

We can now complete the proof of the proposition. Assume  $1 \in I$ . If  $N$  is a submodule of  $R[n]_I$  with simple socle, such that  $|N| = 3$ , then  $N = N_1 + N_2$ , where  $N_1, N_2 \subseteq N \subset R[n]_I$  are of length 2 with simple socle and  $|N_1 \cap N_2| = 1$ . This is because of the following: Since  $N$  is a submodule of  $R[n]_I$ , let  $N^{(1)} \subset R[n]_I^{(1)}$  and  $N^{(2)} \subset R[n]_I^{(2)}$ .  $N$  has length 3 and simple socle, so  $N^{(1)}$  is one-dimensional and  $N^{(2)}$  must have dimension 2, say  $N^{(2)} = \langle x_1, x_2 \rangle$ . Now consider  $Ax_1$ , where  $A$  is the path algebra of the 3-Kronecker quiver:  $x_1$  is not in the socle, thus  $Jx_1 \neq 0$ , where  $J$  is the radical of  $A$ . Then  $Jx_1 \subseteq N^{(1)}$ , and since  $N^{(1)}$  is one-dimensional, we have equality  $Jx_1 = N^{(1)}$ . So  $Ax_1$  has length 2. Now, similarly, consider  $Ax_2$  and conclude by letting  $N_1 = Ax_1$  and  $N_2 = Ax_2$ , both then of length 2 and  $|Ax_1 \cap Ax_2| = 1$ .

Lemma 6.5 then implies that  $N_1$  and  $N_2$  cannot both be of type (a), since then we would have  $|N| = 2$ , a contradiction. Thus we must be in the case of either lemma 6.6 or lemma 6.7, implying  $N_1 + N_2 = R[1]_I$  and therefore  $N = R[1]_I$ .  $\square$

Finally, we will use the following lemma in the next section.

**Lemma 6.8.** *Let  $1 \leq t < n$  and  $t + 1 \in I$ . Let  $V = R[t]_I + Aw$  with  $w = x_{t+1} + \mu y_{t+1}$ , where  $\mu \in k$ . Then  $R[n]_I/V$  has precisely one simple non-projective submodule, namely  $R[t + 1]_I/V$ .*

*Proof.* Since  $t + 1 \in I$  and  $V = R[t]_I + Aw$  with  $w = x_{t+1} + \mu y_{t+1}$ ,  $R[t + 1]_I/V$  has length 1, i.e.  $|R[t + 1]_I/V| = 1$ . To show the lemma, let us look at the possible submodules  $N$  of length 1 of  $R[n]_I/V$  that are not simple projective. We are thus looking at a 1-dimensional top of  $N$  with generator  $u$ , such that we have  $\alpha(u) = 0, \beta(u) = 0, \gamma(u) = 0$  in  $R[n]_I/V$  and  $|N| = 1$ . We have:

$$u = \sum_{j=t+2}^n \lambda_j x_j + \sum_{i=t+1, i \in I}^n \mu_i y_i$$

Applying  $\alpha, \beta, \gamma$ , we get:

$$\alpha(u) = \sum_{j=t+2}^n \lambda_j z_j, \quad \beta(u) = \sum_{j=t+3}^n \lambda_j z_{j-1}, \quad \text{and}$$

$$\gamma(u) = \sum_{i=t+1, i \in I}^n \mu_i z_i,$$

with  $\lambda_j, \mu_i \in k$ , for  $t + 2 \leq j \leq n$ ,  $t + 1 \leq i \leq n$ ,  $i \in I$ . The image of  $u$  under  $\alpha, \beta, \gamma$  vanishes only in one single case:  $\mu_{t+1} \neq 0$ , and for  $j \geq t + 2$ ,  $\lambda_j = 0$ , and  $\mu_i = 0$ , for all  $i \geq t + 2$ ,  $i \in I$ . In all other cases the image would be at least one-dimensional, thus  $N$  would be of length strictly greater than 1, contradicting the fact that  $|N| = 1$ . So  $u = \mu_{t+1} y_{t+1}$ , since we then have  $\alpha(u) = 0 = \beta(u)$  and  $\gamma(u) = \mu_{t+1} z_{t+1}$  which equals 0 in the factor module  $R[n]_I/V$ . Hence  $N = \langle y_{t+1} \rangle$ , which is just  $R[t + 1]_I/V$ .  $\square$

### 6.3 Proof of theorem 6.1

Assume  $1 \in I$ . Let us first collect some results:

**Lemma 6.9.** *Let  $n \geq 2$ . If  $V$  is a submodule of  $R[n]_I$  which contains  $U = R[n-1]_I$  and  $|V| = |U| + 1$ , then  $V$  is decomposable.*

*Proof.* We need to show that there is no indecomposable submodule  $V \subseteq R[n]_I$ , such that  $U \subseteq V$  and  $|V/U| = 1$ . Assume, to get a contradiction,  $V$  is indecomposable. Using the General Structure Lemma 6.1 we know that  $R[n]_I/R[n-1]_I \cong R[1]_J$ , where  $J = \{i - n + 1 \mid i \in I, i > n - 1\}$ . So  $V/U$  is a one-dimensional submodule of  $R[1]_J$  and using proposition 6.4 we get that it is generated by  $z_n$ , i.e.  $V/U = \langle z_n \rangle$ . But then the factor module  $V/U$  is simple projective giving a contradiction, since  $V$  was assumed indecomposable and not simple, so it cannot have a simple projective factor module. We conclude that such submodule  $V$  has to be decomposable.  $\square$

**Lemma 6.10.** *Let  $n \in I$ ,  $n \geq 2$ . Let  $U = R[n-1]_I$  and  $V$  be a submodule of  $R[n]_I$  of the form  $V = U + Aw$  with  $w = x_n + \mu y_n$ , where  $\mu \in k$ . Then  $V$  is indecomposable.*

*Proof.* Assume  $V$  is decomposable  $V = V' \oplus V''$ . Then the restriction of the representation  $V$  to  $\alpha$  and  $\beta$  (thus viewed as a representation over the Kronecker quiver), written  $V|_{(\alpha,\beta)} = V'|_{(\alpha,\beta)} \oplus V''|_{(\alpha,\beta)}$ , which is a decomposition of  $V|_{(\alpha,\beta)}$ . Then  $V|_{(\alpha,\beta)} = X \oplus \langle y_j \mid 1 \leq j \leq n-1 \rangle$ , where  $X$  is indecomposable. If  $\mu = 0$ , then  $V = U + A(x_n)$  is  $R[n]_J$ , where  $J = I \setminus \{n\}$ . By proposition 2.1,  $V = R[n]_J$  is indecomposable. In the case  $\mu \neq 0$ , we have  $V|_{(\alpha,\beta)} \cong R[n]_J|_{\alpha,\beta}$ . But  $\langle y_j \mid 1 \leq j \leq n-1 \rangle$  is injective so then w.l.o.g.  $V''|_{(\alpha,\beta)} \subseteq \langle y_j \mid 1 \leq j \leq n \rangle \subseteq R[n]_I^{(2)}$ . So if  $V$  is decomposable then  $V$  would have a direct summand  $V'' \subseteq \langle y_j \mid j \in I \rangle \subseteq V \subseteq R[n]_I$ , contradicting that  $V$ , as a submodule of  $R[n]_I$ , has no direct summand isomorphic to the injective module  $S_2$  over  $K(3)$ . (To show this: Assume, to get a contradiction,  $S_2$  is a submodule of  $V$ . Then we would have inclusions  $S_2 \subseteq V \subseteq R[n]_I$ . But  $R[n]_I$  is indecomposable and therefore cannot have a simple injective submodule, so  $V$  cannot have  $S_2$  as direct summand.) We conclude  $V = U + Aw$  with  $w = x_n + \mu y_n$ ,  $\mu \in k$ , is indecomposable.  $\square$

*Remark.* Note that there is another submodule  $V$  of  $R[n]_I$  which contains  $U = R[n-1]_I$ , namely  $V = U + Aw$  with  $w = y_n$ . However then  $V$  is decomposable,  $V = U \oplus Aw$ , as seen in the proof of lemma 6.11.

**Lemma 6.11.** *Let  $n \in I$ ,  $n \geq 2$ . The maximal indecomposable submodules of  $R[n]_I$  which contain  $U = R[n-1]_I$ , are the submodules of the form  $U + Aw$  with  $w = x_n + \mu y_n$ , where  $\mu \in k$ .*

*Proof.* Let  $V$  be a maximal indecomposable submodule of  $R[n]_I$  which contains  $U = R[n-1]_I$ . We will show that  $V = U + Aw$  with  $w = x_n + \mu y_n$ , where  $\mu \in k$ .

Let us determine the possibilities for the factor module  $V/U$  having length 2, using proposition 6.4. First note that  $V/U$  is of type (b). Assume, to get a contradiction,  $V/U$  is of type (a). Then since  $U \subset V$ ,  $V = U + Aw$ , with  $w \in \langle x_j, y_i \mid j, i \geq n, i \in I \rangle$ , in the following equation

$$w = \sum_{i \geq n, i \in I} \mu_i y_i, \quad (\mu_i \in k)$$

there exists at least one  $i$ , such that  $\mu_i \neq 0$ . Then  $\alpha(w) = 0 = \beta(w)$ , but  $\gamma(w) = \sum_{i \geq n, i \in I} \mu_i z_i$ , not all  $\mu_i = 0$ . With  $U = R[n-1]_I$  having basis  $x_j, y_i, z_j$ ,  $1 \leq j, i \leq n-1$ ,  $i \in I$ , we would get a direct sum  $V = U \oplus Aw$  giving decomposable  $V$ , a contradiction. So  $V/U$  is of type (b), and since  $n \in I$ ,  $V = U + Aw$  with  $w = x_n + \mu y_n$ ,  $\mu \in k$ .  $\square$

**Lemma 6.12.** *Let  $1 \leq t < n$  and  $U = R[t]_I$  be a submodule of  $R[n]_I$ . If  $V$  is an indecomposable submodule of  $R[n]_I$  which contains  $U$  such that  $|V/U| = 2$ , then  $V$  is a submodule of  $R[t+1]_I$  and has the form  $V = U + Aw$  with  $w = x_{t+1} + \mu y_{t+1}$ ,  $\mu \in k$ , if  $t+1 \in I$ . If  $t+1 \notin I$ , then  $V = U + Aw$  with  $w = x_{t+1}$ , so  $V = R[t+1]_I$ .*

*Proof.* By the General Structure Lemma 6.1 we know that  $R[n]_I/R[t]_I \cong R[n-t]_J$ , where  $J = \{i-t \mid i \in I, i > t\}$ . So  $V/U$  is a length 2 submodule of  $R[n-t]_J$ , so we can apply proposition 6.4: Note that  $V/U$  is of type (b). If not, i.e.  $V/U$  is of type (a), then since  $U \subset V$ ,  $V = U + Aw$ , with  $w \in \langle x_j, y_i \mid t+1 \leq j, i \leq n, i \in I \rangle$ , in the following equation

$$w = \sum_{i \geq t+1, i \in I}^n \mu_i y_i, \quad (\mu_i \in k)$$

there exists at least one  $i$ , such that  $\mu_i \neq 0$ . Then  $\alpha(w) = 0 = \beta(w)$ , but  $\gamma(w) = \sum_{i=t+1, i \in I}^n \mu_i z_i$ , not all  $\mu_i = 0$ . With  $U = R[t]_I$  having basis  $x_j, y_i, z_j$ ,  $1 \leq j, i \leq t, i \in I$ , we would get a direct sum  $V = U \oplus Aw$  giving decomposable  $V$ , a contradiction. So  $V/U$  is of type (b), i.e. if  $t+1 \in I$ , then  $V = U + Aw$  with  $w = x_{t+1} + \mu y_{t+1}$ ,  $\mu \in k$ , and in the case  $t+1 \notin I$ , then  $V = U + Aw$  with  $w = x_{t+1}$ , so  $V = R[t+1]_I$   $\square$

**Corollary 6.13.** *Let  $t < n$ . If  $R[t]_I$  is the unique piling submodule of  $R[n]_I$  of length  $|R[t]_I|$  and  $t+1 \in I$ , then the maximal submodules of  $R[t+1]_I$  that contain  $U = R[t]_I$  and are of the form  $U + Aw$  with  $w = x_{t+1} + \mu y_{t+1}$ , where  $\mu \in k$ , are piling submodules of  $R[n]_I$ .*

*Proof.* Let  $V$  be of the form  $U + Aw$  with  $w = x_{t+1} + \mu y_{t+1}$ , where  $\mu \in k$ , and a maximal submodule of  $R[t+1]_I$  that contains  $U = R[t]_I$ . From lemma 6.10 we know that  $V$  is indecomposable and  $|V| = |U| + 2$ . Since  $U = R[t]_I$  is a piling submodule of  $R[n]_I$  and  $V$  is indecomposable, we know by lemma 6.9 that there is no indecomposable submodule  $U' \subset V$  with  $U \subset U'$  and  $|U'| = |U| + 1$ . Therefore by proposition 5.1,  $V$  is a piling submodule of  $R[n]_I$ .  $\square$

**Corollary 6.14.** *Let  $1 \leq t < n$ . Suppose that  $U = R[t]_I$  is the unique piling submodule of  $R[n]_I$  of length  $|R[t]_I|$ . Then any maximal indecomposable submodule  $V$  containing  $U$ , such that  $|V| = |U| + 2$ , is piling and of the following form:*

1. *If  $t+1 \in I$ , then  $V = U + Aw$  with  $w = x_{t+1} + \mu y_{t+1}$ ,  $\mu \in k$ .*
2. *If  $t+1 \notin I$ , then  $V = U + Aw$  with  $w = x_{t+1}$ , i.e.  $V = R[t+1]_I$ .*

*In particular, if  $t+1 \notin I$ , then  $R[t+1]_I$  is the only piling submodule of length  $|R[t+1]_I|$  that contains  $R[t]_I$ .*

*Proof.* This follows from the above lemmas. By lemma 6.12, since  $V$  is an indecomposable submodule of  $R[n]_I$  containing  $U$  with  $|V/U| = 2$ , we have that  $V$  is a submodule of  $R[t+1]_I$  of the desired form: if  $t+1 \in I$ , then  $V = U + Aw$  with  $w = x_{t+1} + \mu y_{t+1}$ ,  $\mu \in k$ , and if  $t+1 \notin I$ , then  $V = U + Aw$  with  $w = x_{t+1}$ . By corollary 6.13,  $V$  is piling. In the second case, if  $t+1 \notin I$ , then using 6.11,  $V = U + Aw$  with  $w = x_{t+1}$ , i.e.  $V = R[t+1]_I$ , which is just the type (b) submodule of proposition 6.4. Since this is indecomposable and has length  $|U| + 2$ , it is piling by proposition 5.1 (as there is no indecomposable submodule of length  $|U| + 1$  by 6.9).  $\square$

*Proof of theorem 6.1.* The proof is done by induction: assume  $U$  is a piling submodule of  $R[n]_I$  of length at least 3. If  $|U| = |R[m]_I|$  for some  $1 \leq m \leq n$ , then we will show by induction on  $m$  that  $U = R[m]_I$ . This is part (1) of the theorem.

For  $m = 1$ , since  $1 \in I$ , we know by proposition 6.4 that  $R[1]_I$  is the only length 3 submodule of  $R[n]_I$  with simple socle, hence a piling submodule. If  $U$  is a piling submodule of  $R[n]_I$  of length  $|U| = 3 = |R[1]_I|$ , it must have simple socle by proposition 6.4, thus  $U = R[1]_I$ . This completes the base case.

Now we let  $1 \leq t < n$  and assume that  $U = R[t]_I$  is the unique piling submodule of  $R[n]_I$  of length  $|R[t]_I|$ . Let us show that  $R[t+1]_I$  is the unique piling submodule of  $R[n]_I$  of length  $|R[t+1]_I|$ . This is done in two steps: (a)  $R[t+1]_I$  is piling, and (b) if  $W$  is piling of length  $|R[t+1]_I|$ , then  $W = R[t+1]_I$ .

(a) If  $t+1 \in I$ , using lemma 6.11, we know that, the maximal indecomposable submodules of  $R[t+1]_I$ , that contain  $U = R[t]_I$ , are of the form  $U + Aw$ , with  $w = x_{t+1} + \mu y_{t+1}$  ( $U + Ay_{t+1}$  cannot occur, since then it would be decomposable, as in lemma 6.11). By lemma 6.13, the maximal submodules of  $R[t+1]_I$ , that contain  $U = R[t]_I$  are piling submodules. By lemma 6.9, there are no piling submodules  $V$  of length  $|R[t]_I| + 1$ , but there are indecomposable submodules  $V$  of length  $|R[t]_I| + 2$  containing  $R[t]_I$ . Using proposition 5.1, lemma 6.12 and corollary 6.13, those are the piling submodules of length  $|R[t]_I| + 2$  and all of them are submodules of  $R[t+1]_I$ . Since  $t+1 \in I$ , every such  $V$  has the form  $U + Aw$ , with  $w = x_{t+1} + \mu y_{t+1}$ ,  $\mu \in k$ . Now,  $R[t+1]_I$  is indecomposable (by proposition 2.1) and  $R[t+1]_I$  contains  $V$  with  $|R[t+1]_I| = |V| + 1$ . Thus by proposition 5.1, since  $V$  is piling,  $R[t+1]_I$  is piling too.

If  $t+1 \notin I$ , then there is only one piling submodule of  $R[t+1]_I$  of length  $|R[t+1]_I|$ , namely  $R[t+1]_I$  itself, since in this case  $R[t+1]_I = R[t]_I + Ax_{t+1}$ , which is piling by corollary 6.14.

To show part (b), note that by corollary 6.14, we know that  $V$ , such that  $U \subset V \subseteq R[n]_I$  and  $|V/U| = 2$ , is piling and has the form  $V = R[t]_I + Aw$ , with  $w = x_{t+1} + \mu y_{t+1}$ ,  $\mu \in k$ , provided  $t+1 \in I$ . In the case  $t+1 \notin I$ ,  $w = x_{t+1}$ . Furthermore we have that  $V \subseteq R[t+1]_I$  and is indecomposable.

(b) Let  $W$  be a piling submodule of  $R[n]_I$  of length  $|R[t+1]_I|$ . Since both  $W$  and  $R[t+1]_I$  are piling submodules of the same length,  $W$  has piling submodules  $U'$  of length  $|R[t]_I|$  and  $V'$  of length  $|R[t]_I| + 2$ , with  $U' \subset V' \subset W$ . By induction hypothesis,  $R[t]_I$  is the unique piling submodule of length  $|R[t]_I|$ , so we have  $U' = R[t]_I = U$ . Also, by lemma 6.12,  $V'$  is a submodule of  $R[t+1]_I$  of the form  $U + Aw$ , with  $w = x_{t+1} + \mu y_{t+1}$ ,  $\mu \in k$ , provided  $t+1 \in I$ . So we are left to show, that if  $t+1 \in I$ ,  $R[t+1]_I$  is the only indecomposable submodule of  $R[n]_I$ , having length  $|R[t+1]_I|$  and contains  $V' = U + Aw$ , with  $w = x_{t+1} + \mu y_{t+1}$ .

By lemma 6.8, we have that both  $R[n]_I/V$  and  $R[n]_I/V'$  have precisely one simple non-projective submodule, which is  $R[t+1]_I/V$ . Since  $V'$  and  $V$  have length  $|R[t]_I| + 2$ ,  $W$  has length  $|W| = |V'| + 1 = |R[t]_I| + 3$ . Now,  $W = R[t+1]_I$  follows from the General Structure Lemma 6.1: we know that  $R[n]_I/R[t]_I \cong R[n-t]_J$ ,

where  $J = \{i - t \mid i \in I, i > t\}$ . We will again use proposition 6.4. Since  $1 \in I$  and  $W/U$  has simple socle and is of length  $|W/U| = 3$ , part 3 of proposition 6.4 states that if  $1 \in J$ , the only submodule of length 3 of  $R[n - t]_J$  is  $R[1]_J$ . For  $t + 1 \in I$ ,  $W = V' + Ay_{t+1}$  and  $R[t]_I \subset W \subset R[n]_I$  with  $|W| = |R[t]_I| + 3 = |R[t + 1]_I|$ , we have  $1 \in J$  and conclude  $W = R[t + 1]_I$ , for  $t + 1 \in I$ . In the case  $t + 1 \notin I$ , we have already seen that  $R[t + 1]_I = R[t]_I + Ax_{x_{t+1}} = V'$  is the only piling submodule of length  $|R[t + 1]_I|$ , which in this case is just  $V$ .

So  $R[t + 1]_I$  is the unique piling submodule of  $R[n]_I$  of length  $|R[t + 1]_I|$ . This finishes part (1) of theorem 6.1.

Let us prove part (2) and (3) of the theorem. Let  $L$  be a piling submodule of  $R[n]_I$ , of length  $|L| \neq |R[m]_I|$ , for all  $m \leq n$ . Choose  $m$  maximal, such that  $|R[m]_I| \leq |L|$ . Then, by part (1) of the theorem, we have that  $L$  has a piling submodule of length  $|R[m]_I|$ , thus  $R[m]_I$  is a piling submodule of  $L$ . By lemma 6.9, the length of  $L$  cannot be  $|R[m]_I| + 1$ , since else  $L$  would be decomposable. We must have  $|L| = |R[m]_I| + 2$ , which follows from the choice of  $m$  and the following considerations: if  $|L| = |R[m]_I| + 3 = |R[m + 1]_I|$  and  $m \in I$ , then by part (1) of the theorem,  $L = R[m + 1]_I$ , contradicting the fact that  $L$  is a piling submodule of length  $|L| \neq |R[m]_I|$ , for all  $m \leq n$ . If  $m \notin I$ , then if  $|L| = |R[m]_I| + 2 = |R[m + 1]_I|$ , again  $L = R[m + 1]_I$ . So we have  $m \in I$  and  $|L| = |R[m]_I| + 2$ .

By lemma 6.12,  $L$  is a submodule of  $R[m + 1]_I$  and has the form  $R[m]_I + A(x_{m+1} + \mu y_{m+1})$ ,  $\mu \in k$ , since  $m + 1 \in I$ . Such submodules are maximal by lemma 6.11 and piling submodules by corollary 6.13 and corollary 6.14. Since  $\mu \in k$ , we have a one-parameter family of piling submodules of length  $|R[m + 1]_I| - 1$ . This completes part (2), and since  $L$  was chosen to be a piling submodule of  $R[n]_I$ , of length  $|L| \neq |R[m]_I|$ , for all  $m \leq n$ , we also have shown that there are no other piling submodules of length at least 3 than those stated in (1) and (2) of the theorem.

This finishes the proof of theorem 6.1.  $\square$

Note that all submodules of  $R[n]_I$  occurring in a Gabriel-Roiter filtration of  $R[n]_I$  are piling submodules. We can now prove corollary 6.2, stating that any piling submodule of  $R[n]_I$  of length at least 3 belongs to a Gabriel-Roiter filtration of  $R[n]_I$ .

*Proof of corollary 6.2.* Let  $M_1 \subset M_2 \subset \dots \subset M_r$  be a Gabriel-Roiter filtration of  $R[n]_I$  with Gabriel-Roiter measure  $\mu(R[n]_I) = \{l_1, l_2, \dots, l_r\}$ , where  $l_i = |M_i|$  for  $1 \leq i \leq r$ , with  $l_1 < l_2 < \dots < l_r$  and  $l_r = |R[n]_I|$ . Each  $M_i$  is a piling submodule of  $R[n]_I$ . If  $l_i = |R[m]_I|$  for some  $1 \leq m \leq n$ , then theorem 6.1 part (1) implies  $V = R[m]_I$ , so  $M_i = R[m]_I = V$ .

Let  $V$  be a piling submodule of  $R[n]_I$ , such that  $V \neq R[m]_I$ , for  $1 \leq m \leq n$ . Then theorem 6.1 part (2) implies that there exists an  $1 \leq m \leq n$  with  $m + 1 \in I$ ,

such that  $V = R[m]_I + A(x_{m+1} + \mu y_{m+1})$ ,  $\mu \in k$ , and  $V$  has a piling submodule so that  $R[m]_I \subset V \subset R[m+1]_I$ . Then there exists  $i, j$ , with  $i < j < n$ , such that  $M_i = R[m]_I$  and  $M_j = R[m+1]_I$ . By lemma 6.9, there is no indecomposable submodule of  $R[m+1]_I$  of length  $|R[m]_I| + 1$ . Since  $|V| = |R[m]_I| + 2 = |R[m+1]_I| - 1$ , as  $m+1 \in I$ , and  $|V| = |M_j| - 1$  we have that  $j = i+2$  and  $|M_{i+1}| = |V|$ . Hence the chain  $M_1 \subset M_2 \subset \dots \subset M_i \subset V \subset M_{i+2} \subset \dots \subset R[n]_I$  is a Gabriel-Roiter filtration of  $R[n]_I$ .  $\square$

*Remarks.*

1. Recall that  $\mu(R[1]_I) = \{1, 2, 3\}$ , so any Gabriel-Roiter measure of  $R[n]_I$  starts with  $\mu(R[1]_I)$ .
2. Since  $R[m]_I$  is the unique piling submodule of  $R[n]_I$ , for  $m \leq n$ ,  $1 \in I$ ,  $R[m]_I$  occurs in every Gabriel-Roiter filtration of  $R[n]_I$ .

## 6.4 The Gabriel-Roiter measure depends on $I$

Let us prove the following proposition, which follows from the above considerations on piling submodules. It is needed in section 6.7 for the proof of uncountably many Gabriel-Roiter filtrations.

**Proposition 6.15.** *If  $\mu(R[n]_I) = \mu(R[n]_J)$ , then  $I \cap \{1, \dots, n\} = J \cap \{1, \dots, n\}$ .*

*Proof.* Recall that  $R[n]_I$  depends on  $I \cap \{1, 2, \dots, n\}$ . If  $R[n]_I$  and  $R[n]_J$  have the same Gabriel-Roiter measure, we will show by induction on  $t$  that  $I \cap \{1, \dots, t\} = J \cap \{1, \dots, t\}$  for  $1 \leq t \leq n$ . The base case is clear, since if  $t = 1$ , then  $I \cap \{1\} = \{1\} = J \cap \{1\}$ , since  $1 \in I$  and  $1 \in J$ . So we are in the case of the unique piling submodule of length 3 with simple socle,  $R[1]_I$ , as in section 6.2, whose Gabriel-Roiter measure is  $\{1, 2, 3\}$ . Assume that for some  $t$  we have  $I \cap \{1, \dots, t\} = J \cap \{1, \dots, t\}$ . Now look at the case  $t+1 \leq n$ ,  $I \cap \{1, \dots, t+1\}$ . Let  $t+1 \in I$ . Then we know from theorem 6.1 that  $R[n]_I$  has piling submodules  $M$ , of length  $|R[t+1]_I|$ , and  $N$  of length  $|R[t+1]_I| - 1$ . Thus  $\mu(M) = \mu(R[n]_I) \cap \{1, \dots, |R[t+1]_I|\}$  and  $\mu(N) = \mu(R[n]_I) \cap \{1, \dots, |R[t+1]_I| - 1\}$ . Since  $\mu(R[n]_I) = \mu(R[n]_J)$ ,  $R[n]_J$  must have the same piling submodule structure, by definition of the Gabriel-Roiter measure and piling submodules. So  $R[n]_J$  has piling submodules of length  $|R[t+1]_J|$  and  $|R[t+1]_J| - 1$ . If  $t+1 \notin J$ , then  $J \cap \{1, \dots, t+1\} = J \cap \{1, \dots, t\} = I \cap \{1, \dots, t\}$ , by induction, but then using theorem 6.1  $R[n]_J$  has no piling submodules of length  $|R[t+1]_J| - 1$ , giving a contradiction. Therefore  $t+1 \in J$ , which completes the induction.  $\square$

This means that different sets  $I \neq J$  yield different Gabriel-Roiter measures  $\mu(R[n]_I) \neq \mu(R[n]_J)$ .

## 6.5 Case $I = \mathbb{N}_1$

Let us quickly look at the case when  $I = \mathbb{N}_1$ . Let  $n \in \mathbb{N}_1$ . Then  $R[n]_{\mathbb{N}_1}^{(1)}$  is the vector space with basis  $z_i$ ,  $1 \leq i \leq n$ , and  $R[n]_{\mathbb{N}_1}^{(2)}$  the vector space with basis  $x_j, y_i$ , where  $1 \leq j, i \leq n$ . Denote this representation by  $R[n]_{\mathbb{N}_1}$ .

In this case the General Structure Lemma 6.1 implies  $R[n]_{\mathbb{N}_1}/R[m]_{\mathbb{N}_1} \cong R[n-m]_{\mathbb{N}_1}$  and we can prove the following result:

**Lemma 6.16.** *Let  $W$  be a submodule of  $R[n]_{\mathbb{N}_1}$  with a filtration*

$$0 = W_0 \subset W_1 \subset W_2 \subset \dots \subset W_m = W,$$

*such that each factor  $W_i/W_{i-1}$ , for all  $i = 1, \dots, m$ , has a simple socle and length  $|W_i/W_{i-1}| = 3$ . Then  $W = W_m = R[m]_{\mathbb{N}_1}$ .*

*Proof.* We will proceed by induction on  $m$ . The base case,  $m = 1$ , already contains the crucial step: Let  $W \subseteq R[n]_{\mathbb{N}_1}$ , with a filtration  $0 = W_0 \subset W_1 = W$ , such that  $W$  has length 3 and a simple socle. We know that  $R[1]_{\mathbb{N}_1}$  has simple socle and is of length 3, and we have  $R[i]_{\mathbb{N}_1}/R[i-1]_{\mathbb{N}_1} \cong R[1]_{\mathbb{N}_1}$ , for  $1 \leq i \leq n$ .

Since  $W \subseteq R[n]_{\mathbb{N}_1}$  we can choose a minimal  $j$ , such that  $W \subseteq R[j]_{\mathbb{N}_1}$ , but  $W \not\subseteq R[j-1]_{\mathbb{N}_1}$ . W.l.o.g. we can let  $j = n$ . Now consider the following map  $f : W \rightarrow R[1]_{\mathbb{N}_1}$ :

$$W \xrightarrow{u} R[n]_{\mathbb{N}_1} \xrightarrow{v} R[n]_{\mathbb{N}_1}/R[n-1]_{\mathbb{N}_1} \cong R[1]_{\mathbb{N}_1},$$

and note that  $u$  and  $v$  are non-zero. We claim that  $f = v \circ u$  is injective. If not, we have  $\text{Ker}(f) \neq 0$ . But  $W$  has simple socle, so  $\text{soc}(W)$  lies in  $\text{Ker}(f)$ , which means  $f = 0$ , since  $W$  is a submodule of  $R[n]_{\mathbb{N}_1}$  with socle  $R[n]_{\mathbb{N}_1}^{(1)}$ , giving a contradiction. So  $f$  is injective. Furthermore both  $W$  and  $R[1]_{\mathbb{N}_1}$  have simple socle and are of length 3, so  $f$  is an isomorphism.

For the case  $m = 1$  we are left to show that we have equality:  $W = R[1]_{\mathbb{N}_1}$ . For this we use the Process of Simplification: since  $\text{End}(W) = \text{End}(R[1]_{\mathbb{N}_1}) \cong k$ , the category  $\mathcal{F}(R[1]_{\mathbb{N}_1})$  is the full subcategory of  $\text{mod } A$  of all objects with an  $R[1]_{\mathbb{N}_1}$ -filtration. By the process of simplification (see section 2.1 and [Ri8])  $\mathcal{F}(R[1]_{\mathbb{N}_1})$  is exact, extension-closed and abelian, and has as simple object  $R[1]_{\mathbb{N}_1}$ . Then for any  $n$ ,  $R[n]_{\mathbb{N}_1}$  is uniserial in  $\mathcal{F}(R[1]_{\mathbb{N}_1})$ , i.e. has a unique composition series and its submodule lattice is a chain in  $\mathcal{F}(R[1]_{\mathbb{N}_1})$  with simple top and simple socle. Therefore  $W$  is not only isomorphic to  $R[1]_{\mathbb{N}_1}$ , but we also have equality  $W = R[1]_{\mathbb{N}_1}$ .

For the inductive step we now look at the following classes. Define

$$\mathcal{C}_i = \{W_1 \subset W_2 \subset \dots \subset W_i \mid \text{chains of indecomposable submodules} \\ \text{of length } i \text{ in } R[m]_{\mathbb{N}_1}\}$$

inductively as follows:

$$\mathcal{C}_1 = \{S \mid S \text{ is simple submodule of } R[m]_{\mathbb{N}_1}\},$$

$$\mathcal{C}_2 = \{W_1 \subset W_2 \mid W_1 \text{ is simple and } W_2 \subset R[m]_{\mathbb{N}_1} \text{ is indecomposable}\},$$

and with  $\mathcal{C}_i$  being defined, let  $V_1 \subset V_2 \subset \dots \subset V_i \subset V \subseteq R[m]_{\mathbb{N}_1}$  be a chain with  $(V_1 \subset V_2 \subset \dots \subset V_i) \in \mathcal{C}_i$ , and  $V$  indecomposable of smallest length containing  $V_i$ . Then

$$\mathcal{C}_{i+1} = \{W_1 \subset W_2 \subset \dots \subset W_{i+1} \mid (W_1 \subset W_2 \subset \dots \subset W_i) \in \mathcal{C}_i, |W_{i+1}| = |V|\}.$$

Then with  $W_{m-1} = R[m-1]_{\mathbb{N}_1}$ , we have  $V = W_m = R[m]_{\mathbb{N}_1}$ , since their lengths are equal,  $|V| = |W_m| = |R[m]_{\mathbb{N}_1}|$ , and they have a filtration with factors being of length 3 with a simple socle. Therefore, by simplification, we have uniseriality in  $\mathcal{F}(R[1]_{\mathbb{N}_1})$  and so the desired equality.  $\square$

*Remark.* Let  $n \in \mathbb{N}_1$ . Using theorem 6.1 one can show that for any  $1 \leq m \leq n$ ,  $R[n]_{\mathbb{N}_1}$  has a unique piling submodule of length  $|R[m]_{\mathbb{N}_1}| = 3m$ , which is the submodule  $R[m]_{\mathbb{N}_1}$ . Also for any  $2 \leq m \leq n$ , there exists a one-parameter family of piling submodules of length  $|R[m]_{\mathbb{N}_1}| - 1 = 3m - 1$ , namely the maximal submodules of  $R[m]_{\mathbb{N}_1}$  that contain  $R[m-1]_{\mathbb{N}_1}$ .

The proof of this fact can be shorten considerably by using lemma 6.16, since in the construction of the chain  $U \subset V \subset W$  (as in 6.3), one can now argue on the length  $|U| = |R[m]_{\mathbb{N}_1}| = 3m$ ,  $|V| = 3m + 2$ , and  $|W| = |V| + 1 = 3m + 3$ . Since  $W \subset R[n]_{\mathbb{N}_1}$  is a submodule with a filtration such that all factor modules have simple socle and are of length 3, we can apply lemma 6.16 to get  $W = R[m+1]_{\mathbb{N}_1}$  and  $W$  is unique as a piling submodule of  $R[n]_{\mathbb{N}_1}$  of length  $3m + 3 = 3(m + 1)$ .

Finally one can give a closed formula for the Gabriel-Roiter measure of  $R[n]_{\mathbb{N}_1}$ . Using these considerations, the Gabriel-Roiter measure of  $R[m+1]_{\mathbb{N}_1}$  is  $\mu(R[m+1]_{\mathbb{N}_1}) = \mu\{R[m]_{\mathbb{N}_1}\} \cup \{3m + 2, 3m + 3\}$ . With an induction as in theorem 6.1 we then get  $\mu(R[n]_{\mathbb{N}_1}) = \{1, 3l - 1, 3l \mid 1 \leq l \leq n\}$ .

Recall the definition 5.3 of a knotted module: An indecomposable submodule  $U$  of a module  $M$  is called a *knotted module*, provided  $U$  is a piling submodule of  $M$  and  $U$  is unique as piling submodule of  $M$  of length  $|U|$ . For  $1 \leq m \leq n$ ,  $R[n]_{\mathbb{N}_1}$  is a knotted module, since it has a unique piling submodule of length  $|R[m]_{\mathbb{N}_1}| = 3m$ , which is the submodule  $R[m]_{\mathbb{N}_1}$ . Since we have seen that for any  $1 \leq m \leq n$ , there exists a one-parameter family of piling submodules of length  $|R[m+1]_{\mathbb{N}_1}| - 1 = 3m - 1$ , one can picture  $R[n]_{\mathbb{N}_1}$  as follows: The one-parameter family of maximal submodules of  $R[m]_{\mathbb{N}_1}$  that contain  $R[m]_{\mathbb{N}_1}$  are drawn as dots between the knotted modules. Note that in the case of  $R[1]_{\mathbb{N}_1}$ , one has the additional Gabriel-Roiter submodule generated by  $\langle y_1 \rangle$  of length 2.

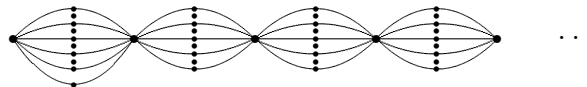

## 6.6 $R[n]_I$ and dimension vectors

Let  $I \subset \mathbb{N}_1$  and  $1 \in I$  and let us come back to the more general situation with representations  $R[n]_I$  with corresponding  $k$ -spaces  $R[n]_I^{(1)}$ ,  $R[n]_I^{(2)}$ , where the latter now has basis  $x_j, y_i$ , where  $1 \leq j \leq n$ , and  $1 \leq i \leq n$  with  $i \in I$ . Then  $R[n]_I$  only depends on  $I \cap \{1, 2, \dots, n\}$  and not on  $I$  itself. We have the following properties of  $R[n]_I$ , depending on  $I$ :

$$\min\{\mathbf{dim} R[n]_I\} = (n, n+1) \text{ and } \max\{\mathbf{dim} R[n]_I\} = (n, 2n).$$

Unfortunately this range of dimension vectors does not even cover half of the possible dimension vectors of regular representations, since the imaginary roots of the quiver  $K(3)$  are all  $(n, m) \in \mathbb{N}^2$  with  $\frac{3-\sqrt{5}}{2} < \frac{n}{m} < \frac{3+\sqrt{5}}{2}$ . Let  $n < d \leq 2n$ , then  $\min\{q((n, d))\} = q((n, 2n)) = q((n, n)) = -n^2$ ,  $\max\{q((n, d))\} = q((n, \lfloor 3n/2 \rfloor)) = \lfloor -5n^2/4 \rfloor$ , and the length of  $R[n]_I$  is a positive integer between  $2n+1$  and  $3n$ .

The Gabriel-Roiter measure of  $R[n]_I$  depends on  $I \cap \{1, 2, \dots, n\}$  and we have seen in the previous sections that in the case  $I = \mathbb{N}_1$ , i.e.  $R[n]_{\mathbb{N}_1}$ , the Gabriel-Roiter measure is  $\{1, \dots, 3i-1, 3i, \dots, 3n-1, 3n\}$ ,  $1 \leq i < n$  and  $3n$  being the length of  $R[n]_I$ . In this case  $R[n]_I$  has dimension vector  $\mathbf{dim} R[n]_I = (n, 2n)$ . Drawn as a coefficient quiver  $R[n]_{\mathbb{N}_1}$  looks like (here  $n = 7$ ):

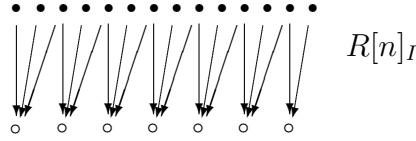

Let us now look at the case when  $I = \{1\}$ , so  $1 \in I$  is the only element of  $I$ . Then  $R[n]_I$  has dimension vector  $\mathbf{dim} R[n]_I = (n, n+1)$ . The Gabriel-Roiter measure of  $R[n]_I$  can be computed and turns out to be  $\mu(R[n]_{\{1\}}) = \{1, 2, \dots, 2i-1, \dots, 2n+1\}$  for  $1 < i \leq n$ ,  $2n+1$  being the length of  $R[n]_I$ . Drawn as a coefficient quiver  $R[n]_I$  looks like (case  $n = 7$ ):

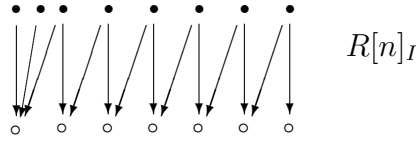

Finally, applying theorem 6.1 together with its corollary we can give a recursive formula for the Gabriel-Roiter measure of  $R[n]_I$  in general.

**Theorem 6.17.** *Let  $I \subset \mathbb{N}_1$  and  $1 \in I$ . Let  $n \in \mathbb{N}_1$  and  $R[n]_I$  a representation of length  $r \geq 3$  with Gabriel-Roiter filtration  $W_1 \subseteq W_2 \subseteq \dots \subseteq W_r = R[n]_I$ . Let  $\{l_1, l_2, l_3, \dots, l_r\}$  be the Gabriel-Roiter measure of  $R[n]_I$ , where  $l_i = |W_i|$ , for  $1 \leq i \leq r$ . Then*

(i)  $l_1 = 1, l_2 = 2, l_3 = 3$ , i.e. the Gabriel-Roiter measure of  $R[n]_I$  starts with  $\{1, 2, 3\}$ .

(ii) for  $i \geq 3$ ,

$$l_i = l_{i-1} + \begin{cases} 2, & \text{if } l_{i-1} - l_{i-2} = 1 \text{ or } \dim(\text{soc } W_{i-1}) + 1 \notin I \\ 1, & \text{else} \end{cases}$$

Our interest lies in constructing uncountably many Gabriel-Roiter measures, which is done in the next section.

## 6.7 Uncountably many Gabriel-Roiter measures

### 6.7.1 Infinite Gabriel-Roiter filtration

When working with the definition of the Gabriel-Roiter measure of an infinite length module  $M$  one gets similar results. If  $M$  is not of finite length, let  $\mu(M)$  be the supremum of the numbers  $\mu(M')$  taken over all (indecomposable) submodules  $M'$  of  $M$  of finite length. As Gabriel-Roiter filtration one defines the following: Let  $M$  be a module which is not finitely generated. A sequence  $M_1 \subset M_2 \subset \dots \subset M_t \subset \dots$  is called a *Gabriel-Roiter filtration* of  $M$  provided the following conditions are satisfied:

- (i)  $M_1$  is a simple module.
- (ii)  $M_{i-1}$  is a Gabriel-Roiter submodule of  $M_i$ , for all  $i \geq 2$ .
- (iii)  $M = \bigcup_i M_i$ .

Recall theorem 3.1 from section 3:

**Theorem 6.18.** *Any module  $M$  with a Gabriel-Roiter filtration is indecomposable.*

We will use this result to extend our results from previous sections on finitely generated modules to infinitely generated modules.

### 6.7.2 Definition of $R[\infty]_I$

In contrast to the previous sections, we consider an infinitely generated module  $R[\infty]_I$  for a given set  $I \subseteq \mathbb{N}_1$ . Define the representation  $R[\infty]_I$  for the quiver  $K(3)$  analogous to the finitely generated case: the vector space  $R[\infty]_I^{(1)}$  has basis  $z_i$ ,  $i = 1, 2, \dots$ , the vector space  $R[\infty]_I^{(2)}$  has basis  $x_j, y_i$ , where  $j = 1, 2, \dots$ , and  $i \in I$ , which can be a finite or infinite set. Let

$$\begin{aligned} \alpha(x_j) &= z_j, \beta(x_j) = z_{j-1}, \text{ and } \gamma(x_j) = 0, \\ \alpha(y_i) &= 0, \beta(y_i) = 0, \text{ and } \gamma(y_i) = z_i, \end{aligned}$$

for all  $i, j$ , with  $i \in I$ , and where  $z_0 = 0$ . Define  $R[0]_I = 0$ . Again we assume  $1 \in I$ .

*Remark.* The module  $M_i$ , for  $i \geq 2$ , of the infinite Gabriel-Roiter filtration  $M_1 \subset M_2 \subset M_3 \subset \dots \subset \bigcup_n M_n = R[\infty]_I$  lies in the central part of  $\text{mod } A$ , where  $A$  is the path algebra of the quiver  $K(3)$ .  $R[\infty]_I$  is an infinite-dimensional module in the central part.

### 6.7.3 Uncountably many $R[\infty]_I$

Let  $I \subseteq \mathbb{N}_1$  with  $1 \in I$ . The classification of piling submodules in theorem 6.1 also holds for the infinitely generated module  $R[\infty]_I$ : Every piling submodule is finitely generated and a submodule of  $R[n]_I$  for some  $n \in \mathbb{N}_1$ . We have inclusion maps  $R[0]_I \subset R[1]_I \subset R[2]_I \subset \dots \subset R[n]_I \subset \dots \subset R[\infty]_I$ . Our theorem 6.1 extends to this case:

**Theorem 6.19.** *Let  $I \subseteq \mathbb{N}_1$  with  $1 \in I$ . Then the piling submodules of  $R[\infty]_I$  of length at least 3 are of two kinds:*

- (1) *For any  $m \in \mathbb{N}_1$  there exists a unique piling submodule of length  $|R[m]_I|$ , which is the submodule  $R[m]_I$ .*
- (2) *For any  $2 \leq m \in \mathbb{N}_1$  with  $m \in I$ , there exists a one-parameter family of piling submodules of length  $|R[m]_I| - 1$ , namely the maximal submodules of  $R[m]_I$  that contain  $R[m-1]_I$ .*

As mentioned in the introduction, C.M. Ringel has conjectured that there are only countably many Gabriel-Roiter measures in the case of a tame algebra. There exists an unpublished proof for the tame hereditary case. In our case of the wild hereditary 3-Kronecker quiver we can construct uncountably many infinite Gabriel-Roiter measures.

Recall from section 6.4, that that different sets  $I \neq J$  yield different Gabriel-Roiter measures, and there is a one-to-one correspondence between  $I$  and  $R[\infty]_I$ , since different  $I$  induce non-isomorphic  $R[\infty]_I$  with different Gabriel-Roiter measures. The next theorem now follows directly:

**Theorem 6.20.** *There are uncountably many Gabriel-Roiter measures for modules  $R[\infty]_I$  with  $I \subseteq \mathbb{N}_1$ .*

*Proof.* Let  $I_1$  and  $I_2$  be two subsets of  $\mathbb{N}_1$ , such that  $I_1 \neq I_2$ . Then applying proposition 6.15,  $R[\infty]_{I_1}$  and  $R[\infty]_{I_2}$ , have different Gabriel-Roiter measures. Assume there would only be countably many such sets  $I_i$ . Then we can list them  $\Psi = [I_1, I_2, I_3, I_4, \dots]$ . However, using Cantor's diagonal argument we can construct a new set  $I'$  not in this list. Then  $I'$  is different from all  $I_i$  in  $\Psi$ , contradicting the fact that  $\Psi$  contains all such sets. Therefore  $\Psi$  is incomplete and hence we have uncountably many such sets  $I_i$ . By proposition 6.15 we get uncountably many Gabriel-Roiter measures  $\mu(R[\infty]_{I_i})$ , since different sets yield different Gabriel-Roiter measures.  $\square$

**Corollary 6.21.** *The central part of  $\text{mod } A$  contains uncountably many Gabriel-Roiter measures. Thus there exists uncountably many indecomposable infinite-dimensional modules in the central part of  $\text{mod } A$ .*

## 7 Link to Fibonacci numbers

Recall that the Fibonacci numbers are given by the sequence  $(a_n)_n$  with  $a_{n+1} = a_n + a_{n-1}$  for  $n \geq 1$  and  $a_0 = 0$ ,  $a_1 = 1$ . Also  $\lim_{n \rightarrow \infty} \left(\frac{a_{n-1}}{a_n}\right) = \frac{-1+\sqrt{5}}{2}$ . Written in matrix form one gets:

$$\begin{pmatrix} 1 & 1 \\ 1 & 0 \end{pmatrix} \begin{pmatrix} a_n \\ a_{n-1} \end{pmatrix} = \begin{pmatrix} a_{n+1} \\ a_n \end{pmatrix}$$

Here is how the Fibonacci-sequence starts:

$$0, 1, 1, 2, 3, 5, 8, 13, 21, 34, 55, 89, 144, 233, 377, 610, 987, \dots$$

For  $n \geq 1$  let  $v_n = \begin{pmatrix} a_n \\ a_{n-1} \end{pmatrix}$ , which is a vector in  $\mathbb{R}^2$ . So we can picture some of these vectors in the following figure 2. We have the famous Binet formula for the

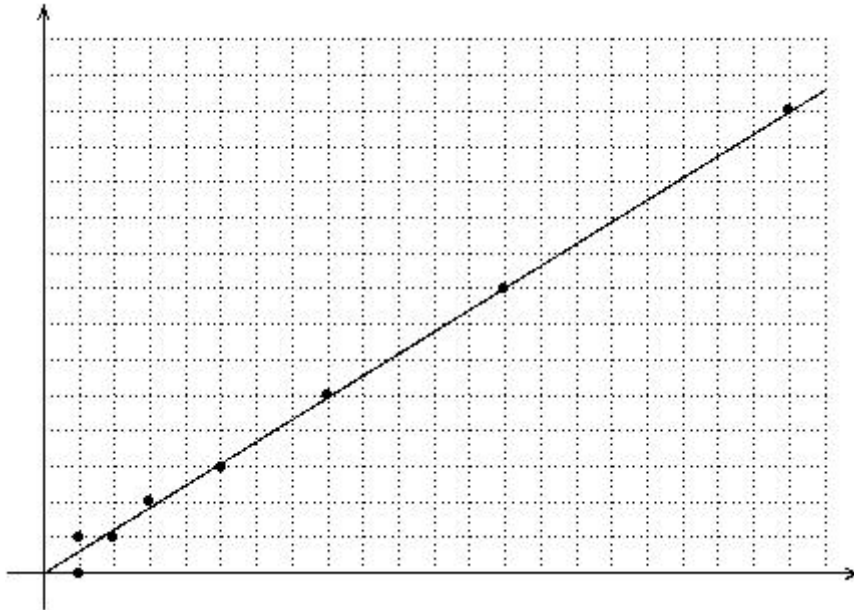

Figure 2: First eight vectors  $v_1, \dots, v_8$  of the Fibonacci sequence.

$n$ th Fibonacci number<sup>9</sup>:

$$a_n = \frac{1}{\sqrt{5}} \left( \left( \frac{1+\sqrt{5}}{2} \right)^n - \left( \frac{1-\sqrt{5}}{2} \right)^n \right)$$

<sup>9</sup>This was published in 1842 by Binet, but the formula was already known to Euler and D. Bernoulli.

## 7.1 Slope for the 3-Kronecker

Recall the Tits form for the 3-Kronecker quiver for a dimension vector  $(x, y)$ , which is given by  $q((x, y)) = x^2 + y^2 - 3xy$ . Solving the equation  $q((x, y)) = 0$  one gets the two possible solutions for  $x$  in relation to  $y$ :  $x_1 = (\frac{3+\sqrt{5}}{2})y$ , and  $x_2 = (\frac{3-\sqrt{5}}{2})y$ . Thus we get two lines in the plane, one with slope  $\frac{3+\sqrt{5}}{2}$ , the other with slope  $\frac{3-\sqrt{5}}{2}$ . These lines are the asymptotes for the equation  $q((m, n)) = 1$ . This reflects the dual situation of preprojective and preinjective modules, since the integer solutions  $(m, n) \in \mathbb{N}_1^2$  for  $q((m, n)) = 1$  are just the dimension vectors for indecomposable preprojective and indecomposable preinjective modules for the 3-Kronecker quiver. Drawing these dimension vectors in the plane one sees that the preinjective dimension vectors just lie below the line with slope  $\frac{3-\sqrt{5}}{2}$ . As an infinite fractional chain we have ( $\varphi$  denoting the Golden Ratio):

$$1 + \sqrt{5} - \varphi = \frac{3 - \sqrt{5}}{2} = \frac{2}{5 + \frac{1}{4 + \frac{1}{4 + \frac{1}{4 + \frac{1}{\dots}}}}}$$

We will be interested in those dimension vectors  $(m, n) \in \mathbb{N}_1^2$  which lie just above this line. Since the 3-Kronecker quiver is a hyperbolic quiver we know by a theorem of Kac that for every such dimension vector there is an imaginary root, thus an indecomposable representation. The link between Fibonacci numbers and dimension vectors is well known. For instance, note that the numbers occurring in the dimension vectors of the preprojective and preinjective indecomposable modules are just every second, that is the even indexed Fibonacci numbers. Together with C.M. Ringel we gave a new partition formula (see [FR]) for these even index Fibonacci numbers in the case of exceptional dimension vectors (i.e. those on the curve  $q(d) = 1$ ). In chapter 8 we will give a similar formula for odd index Fibonacci numbers, which occur in the dimension vectors of certain indecomposable regular modules for the 3-Kronecker quiver. These dimension vectors lie on the curve  $q(d) = -1$ , i.e. have 2 parameters.

Let us first look at the sequence of dimension vectors lying above the slope in the 3-Kronecker case, discussed next.

## 7.2 Dimension vectors

Let us consider the following infinite sequence  $\mathcal{D}$  of dimension vectors:

$$\mathcal{D} : \quad \binom{1}{1}, \binom{2}{1}, \binom{3}{2}, \binom{4}{2}, \binom{5}{2}, \binom{6}{3}, \binom{7}{3}, \binom{8}{4}, \binom{9}{4}, \binom{10}{4}, \binom{11}{5}, \binom{12}{5}, \binom{13}{5}, \binom{14}{6}, \binom{15}{6}, \dots$$

These are the dimension vectors  $(m, n) \in \mathbb{N}_1^2$  which lie just above the line with slope  $\frac{3-\sqrt{5}}{2} = 1 + \sqrt{5} - \varphi$  coming from the solutions to the equation  $q((m, n)) = 0$ . Let us denote by  $\mathbf{d}_n$  the  $n$ th dimension vector in the above list, i.e. the dimension vector at position  $n$ , which is just the upper entry of  $\mathbf{d}_n = \binom{n}{m} \in \mathbb{N}^2$ . These

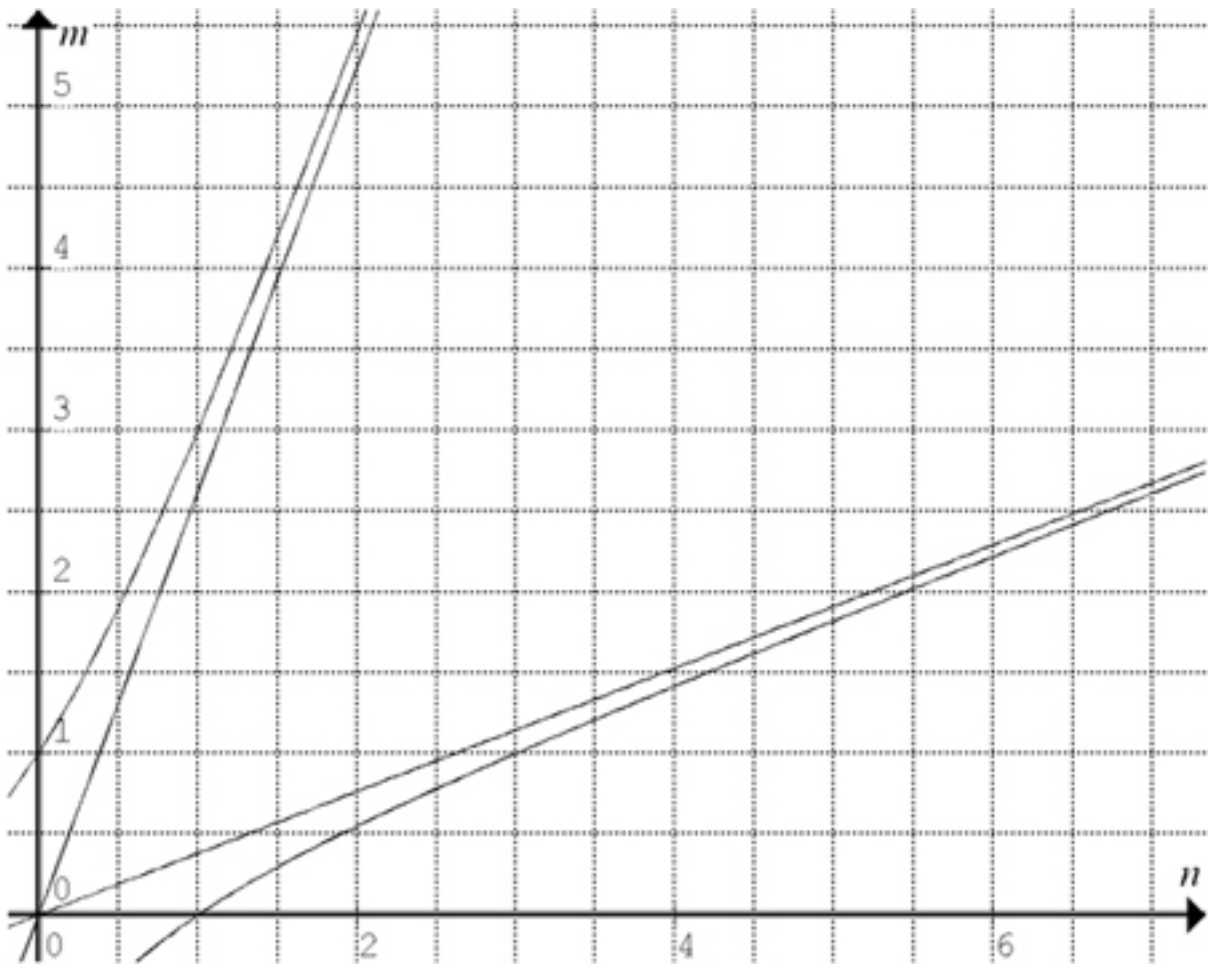

Figure 3: Tits form equations  $q(\mathbf{d}) = 0$  and  $q(\mathbf{d}) = 1$ .

dimension vectors occur naturally as imaginary roots of the 3-Kronecker quiver and the sequence  $\mathcal{D}$  can be described as follows: For every  $n$ ,  $m$  is the smallest value, such that  $\frac{n}{m} < \frac{3+\sqrt{5}}{2}$ . That means, for any other dimension vector  $\binom{n}{m'} \in \mathbb{N}^2$ , such that  $\frac{n}{m'} < \frac{3+\sqrt{5}}{2}$ ,  $m \leq m'$ .

One hopes to be able to construct indecomposable representations  $M_n$  for each of the dimension vectors  $\mathbf{d}_n$  in the sequence  $\mathcal{D}$ . We then have for a module  $M$  with  $\mathbf{dim}(M) = \mathbf{d}_n$ ,  $n = \dim \text{top}(M)$ . Describing properties and a formula for the sequence  $\mathcal{D}$  will be done in this chapter, construction of all the corresponding indecomposable modules is still an open problem, with some evidence of a general construction given in chapter 9.

Recursively what one does to get the dimension vectors in the sequence  $\mathcal{D}$  is the following: One keeps adding the dimension vector  $\binom{1}{1}$  to  $\mathbf{dim} M_i$  to get  $\mathbf{dim} M_j$ , as long as the Tits form  $q(\mathbf{dim} M_j)$  is still  $\leq -1$ . If not, one adds the

dimension vector  $\binom{1}{1}$ . Then the dimension of the top always increases by 1 in the Gabriel-Roiter filtration, whereas the dimension of the socle only increases by 1 in case the Tits form would take a value greater than  $-1$ .

Recall that the *floor function* of a real number  $x$ , denoted by  $\lfloor x \rfloor$ , is a function that returns the largest integer less than or equal to  $x$ . Formally, for  $x \in \mathbb{R}$  we define:  $\lfloor x \rfloor = \max\{n \in \mathbb{Z} \mid n \leq x\}$ . Dually one defines the *ceiling function* to be the smallest integer not less than  $x$ . Let us compute the dimension vector  $\mathbf{d}_n$  in  $\mathcal{D}$  for every  $n$ :

**Lemma 7.1.** *For every  $n \in \mathbb{N}$ ,  $\mathbf{d}_n = \binom{n}{2n - \lfloor n\varphi \rfloor}$ , where  $\varphi = \frac{1+\sqrt{5}}{2}$  is the golden ratio and  $\lfloor \cdot \rfloor$  denotes the floor function.*

*Proof.* Thus for a dimension vector  $\binom{n}{m}$  we need to show  $m = 2n - \lfloor n\varphi \rfloor$ . Let  $\binom{n}{y}$  be the point lying on the line  $q((x, y)) = 0$ . Then  $y = n\frac{3-\sqrt{5}}{2}$ , since  $\frac{3-\sqrt{5}}{2}$  is the slope of the line. But the positive integer  $m$  is just the next integer above  $y$ , thus, when using the ceiling function, can be written as  $m = \lceil n\frac{3-\sqrt{5}}{2} \rceil$ . With  $\frac{3-\sqrt{5}}{2} = 1 + \varphi - \sqrt{5}$  we get  $m = \lceil n(1 + \varphi - \sqrt{5}) \rceil = n + \lceil n(\varphi - \sqrt{5}) \rceil = n + \lceil n/2 - n\sqrt{5}/2 \rceil = 2n + \lceil -n/2 - n\sqrt{5}/2 \rceil$ , with the last equality because the difference between  $\lceil -n/2 - n\sqrt{5}/2 \rceil$  and  $\lceil n/2 - n\sqrt{5}/2 \rceil$  is just  $n$ . Now  $m = 2n + \lceil -n/2 - n\sqrt{5}/2 \rceil = 2n + \lceil -n(1 + \sqrt{5})/2 \rceil = 2n + \lceil -n\varphi \rceil = 2n - \lfloor n\varphi \rfloor$ , since for any  $x \in \mathbb{R}$ ,  $\lceil x \rceil = -\lfloor -x \rfloor$ .  $\square$

Recall the Tits form of a dimension vector  $\binom{n}{m}$  for the 3-Kronecker quiver:  $q\left(\binom{n}{m}\right) = n^2 + m^2 - 3nm$ . Calculating the Tits form for the dimension vectors in  $\mathcal{D}$  one obtains:

$\mathbf{d}_n$	$\binom{1}{1}$	$\binom{2}{1}$	$\binom{3}{2}$	$\binom{4}{2}$	$\binom{5}{2}$	$\binom{6}{3}$	$\binom{7}{3}$	$\binom{8}{4}$	$\binom{9}{4}$	$\binom{10}{4}$	$\binom{11}{5}$	$\binom{12}{5}$	$\binom{13}{5}$ ...
$q(\mathbf{d}_n)$	-1	-1	-5	-4	-1	-9	-5	-16	-11	-4	-19	-11	-1 ...

*Remark.* The sequence of values of  $q(\mathbf{d}_n)$ ,  $-1, -1, -5, -4, -1, -9, -5, -16, -11, \dots$ , is a self-repeating sequence. It is sequence number A005752 in N. J. A. Sloane's *The On-Line Encyclopedia of Integer Sequences*<sup>10</sup>. This sequence is also closely related to the *Lower & Upper Wythoff sequence*, which is sequence number A000201 resp. A001950. It further turns out that the Wythoff sequences partition the dimension vectors in  $\mathcal{D}$  into dimension vectors of knotted modules and non-knotted modules. These sequences are also Beatty sequences, i.e. they partition the natural numbers. Further investigation is needed to fully understand the representation-theoretical interpretation of these links.

**Proposition 7.2.** *The value of the Tits form of a dimension vector  $\mathbf{d}_n \in \mathcal{D}$  is*

$$q(\mathbf{d}_n) = -n^2 - n\lfloor n\varphi \rfloor + \lfloor n\varphi \rfloor^2,$$

where  $\varphi = \frac{1+\sqrt{5}}{2}$  is the golden ratio and  $\lfloor \cdot \rfloor$  denotes the floor function.

<sup>10</sup>[www.research.att.com/~njas/sequences](http://www.research.att.com/~njas/sequences)

*Proof.* We have  $q(\mathbf{d}_n) = q\left(\binom{n}{m}\right) = n^2 + m^2 - 3nm$  and from lemma 7.1  $m = 2n - \lfloor n\varphi \rfloor$ . So  $q(\mathbf{d}_n) = n^2 + (2n - \lfloor n\varphi \rfloor)^2 - 3n(2n - \lfloor n\varphi \rfloor) = -n^2 - n\lfloor n\varphi \rfloor + \lfloor n\varphi \rfloor^2$ .  $\square$

*Remark.* Of course one can generalise the above formulae for  $n$ -Kronecker quivers, taking into account the slope of the line defined by  $q(\mathbf{d}) = 0$ . For example, for the 4-Kronecker quiver the  $n$ th dimension vector in the analogous defined sequence  $\mathcal{D}_4$  is  $\binom{n}{2n - \lfloor n\sqrt{3} \rfloor}$ . However, the 3-Kronecker quiver is special in a way, since this is the only case where the Golden Ratio plays an important role.

### 7.3 Gabriel-Roiter measure of $\mathcal{D}$

We conjecture the existence of an infinite-dimensional module  $M_\infty$  with infinite Gabriel-Roiter filtration  $M_0 \subset M_1 \subset \dots \subset M_n \subset \dots$  and  $\mathbf{dim}(M_n) = \mathbf{d}_n \in \mathcal{D}$ , for all  $n = 1, 2, \dots$ . If such a module  $M_\infty$  exists, we give a formula for the Gabriel-Roiter measure of an indecomposable module  $M$  of dimension vector  $\mathbf{d}$  lying in the sequence  $\mathcal{D}$ .

**Theorem 7.3.** *Assume there is an infinite-dimensional module  $M_\infty$  with infinite Gabriel-Roiter filtration  $M_0 \subset M_1 \subset \dots \subset M_n \subset \dots$  and  $\mathbf{dim}(M_n) = \mathbf{d}_n \in \mathcal{D}$ , for all  $n = 1, 2, \dots$ , where  $\mathcal{D}$  is the infinite sequence of dimension vectors*

$$\binom{1}{1}, \binom{2}{1}, \binom{3}{2}, \binom{4}{2}, \binom{5}{2}, \dots, \binom{n}{2n - \lfloor n\varphi \rfloor}, \dots$$

*Then the Gabriel-Roiter measure of an indecomposable module  $M_n$  of dimension vector  $\mathbf{d}_n$  is  $\{1, l_1, l_2, l_3, \dots, l_n\}$ , where  $l_i = 3i - \lfloor i\varphi \rfloor$ , for  $1 \leq i \leq n$ , and  $\varphi = \frac{1+\sqrt{5}}{2}$  is the golden ratio and  $\lfloor \cdot \rfloor$  denotes the floor function.*

*Proof.* Recall from corollary 7.1 the  $i$ th dimension vector in the sequence  $\mathcal{D}$ , which is  $\binom{i}{2i - \lfloor i\varphi \rfloor}$ . The length of the module  $M_i$  with  $\mathbf{dim}(M_i) = \mathbf{d}_i = \binom{i}{m}$  is  $l_i = |M_i| = n + m = i + 2i - \lfloor i\varphi \rfloor = 3i - \lfloor i\varphi \rfloor$ .  $\square$

We want to conjecture the existence of a largest Gabriel-Roiter measure in the central part and that the infinite-dimensional module  $M_\infty = \bigcup M_n$ , with  $\mathbf{dim}(M_n) = \mathbf{d}_n \in \mathcal{D}$ , for all  $n = 1, 2, \dots$ , has the following Gabriel-Roiter measure:

**Definition 7.1.** *Since the sequence of Gabriel-Roiter measures of  $\mathcal{D}$  is closely related to the Fibonacci sequence, we call it the  $\mathcal{F}$ -Gabriel-Roiter measure. Thus*

$$\mathcal{F} = \{1, 2, 3, 5, 6, 7, 9, 10, 12, 13, 14, 16, 17, 18, 20, 21, 23, 24, 25, \dots, 3i - \lfloor i\varphi \rfloor, \dots\},$$

*with  $\varphi = \frac{1+\sqrt{5}}{2}$  being the golden ratio and  $\lfloor \cdot \rfloor$  the floor function.*

The letter  $\mathcal{F}$  also stands for *full*, since the  $\mathcal{F}$ -Gabriel-Roiter measure is numerically the fullest measure in the central part, as conjectured next: Recall that for any algebra  $A$  of infinite representation type, there are Gabriel-Roiter measures  $I_t, I^t$  with  $I_1 < I_2 < I_3 < \dots < I^3 < I^2 < I^1$ , such that any other Gabriel-Roiter measure  $I$  for  $A$  satisfies  $I_t < I < I^t$  for all  $t \in \mathbb{N}_1$ .

**Conjecture 1.** The  $\mathcal{F}$ -Gabriel-Roiter measure is the infinite Gabriel-Roiter measure  $J$  for the 3-Kronecker quiver, such that  $J < I^t$  for all  $t \in \mathbb{N}$  and  $I \leq J$  for all other Gabriel-Roiter measures  $I$ .

**Theorem 7.4.** *The  $\mathcal{F}$ -Gabriel-Roiter measure as infinite sum is irrational:*

$$\sum_{i=1}^{\infty} \frac{1}{2^{3n - \lfloor n\varphi \rfloor}} \notin \mathbb{Q}$$

*Proof.* Note first that  $\mathcal{F}(n) = 3n - \lfloor n\varphi \rfloor$  is a strictly increasing sequence and let us first show that the sequence is not of the form  $\mathcal{A}(n) = \mathcal{A}(n+p) + s$ , where  $p$  denotes the period and  $s$  is an integer. If it were, then the slope of the sequence would be  $s/p$ , which is a rational number, since  $s, p$  are integers. This contradicts the fact that the slope of  $\mathcal{F}(n)$  is  $3 - \varphi$ , an irrational number, since  $\varphi = (1 + \sqrt{5})/2$  is the Golden Ratio. Hence  $\mathcal{F}(n) = 3n - \lfloor n\varphi \rfloor$  is not of the form  $\mathcal{A}(n) = \mathcal{A}(n+p) + s$ , which implies that the binary expansion of the infinite sum  $\sum_{i=1}^{\infty} \frac{1}{2^{3n - \lfloor n\varphi \rfloor}}$  is not eventually periodic. But this infinite sum is just the definition of the Gabriel-Roiter measure, hence it is an irrational number.  $\square$

**Conjecture 2.** The Gabriel-Roiter measure of  $M_{\infty} = \bigcup M_n$  is

$$\mu(M_{\infty}) = \mathcal{F}.$$

Furthermore,  $M_{\infty}$  can be obtained as the direct limit

$$M \subset \tau M \subset \tau^2 M \subset \dots \subset \bigcup_{n=1}^{\infty} \tau^n M = M_{\infty},$$

where  $M$  is an indecomposable regular module with dimension vector  $\mathbf{dim} M = (1, 1)$ .

Further investigations into the structure of  $M_{\infty}$  can be found in chapter 9 and in particular in section 9.3. For the moment, let us just recall that in contrast to the tame case, there are no non-zero torsion-free divisible modules (see [Ri5]) over a wild hereditary algebra. The following example of an indecomposable divisible module was originally constructed by O. Kerner and given in F. Lukas ([L1]):

*Example.* Let  $X \neq 0$  be a regular module with  $\mathcal{O}(X)$  a regular mono-orbit<sup>11</sup>. Then there is a non-zero map  $f : X \rightarrow \tau^n X$  for some  $n$ .<sup>12</sup> Considering the following chain of monomorphisms:

$$X \xrightarrow{f} \tau^n X \xrightarrow{\tau^n f} \tau^{2n} X \xrightarrow{\tau^{2n} f} \tau^{3n} X \hookrightarrow \dots,$$

define  $M := \bigcup_r \tau^{rn} X$ . Let  $U$  be a non-zero finitely generated submodule of  $M$  with  $U \subset \tau^{rn} X \subset M$  for some  $r \in \mathbb{N}$ . Since  $\mathcal{O}(X)$  is a regular mono-orbit the

<sup>11</sup>This means that for all  $R$  regular and  $n \in \mathbb{N}_0$ , all non-zero maps in  $\text{Hom}(\tau^n X, R)$  are monomorphisms.

<sup>12</sup>This fact uses Baer's theorem (see [L1], Prop. 1.6).

modules  $(\tau^{(r+i)n}X)/U$  are preinjective for all  $i \in \mathbb{N}$ , otherwise we have the epimorphism and thus an isomorphism from  $\tau^{(r+i)n}X$  onto a regular direct summand of  $(\tau^{(r+i)n}X)/U$ , which is a contradiction. The factor module  $M/U$  is an epimorphic image of  $\bigoplus(\tau^{(r+i)n}X)/U$  and therefore a direct sum of preinjective modules.

Let  $I$  be an indecomposable preinjective module. Look at the short exact sequence  $0 \rightarrow U \rightarrow M \rightarrow M/U \rightarrow 0$  and apply  $\text{Hom}(I, -)$  to get:

$$\dots \rightarrow \text{Hom}(I, M) \rightarrow \text{Hom}(I, M/U) \rightarrow \text{Ext}(I, U) \rightarrow \dots$$

Since  $\text{Hom}(I, M) = 0$  the module  $M/U$  has only finitely many direct summands isomorphic to  $I$ . So we can write  $M/U$  as  $\bigoplus_n I_n^{k_n}$  with pairwise non-isomorphic indecomposable preinjective modules  $I_n$  and  $k_n \in \mathbb{N}$ . Since every proper factor of  $M$  is a direct sum of preinjective modules, a non-zero map  $M \rightarrow N$  has to be a monomorphism. In particular,  $M$  is an indecomposable divisible module.

Let us also recall briefly the situation in the tame hereditary case:

*Example.* Let  $A$  be a tame hereditary algebra and  $S(1)$  a simple regular module. If

$$S(1) \hookrightarrow S(2) \hookrightarrow S(3) \hookrightarrow \dots$$

is a chain of irreducible monomorphisms, then the module  $S := \bigcup_n S(n)$  is an indecomposable torsion divisible module with local endomorphism ring. This is a Prüfer module. In the tame case every torsion divisible module is a direct sum of indecomposable preinjective modules and Prüfer modules.

Finally, let us propose the following definition:

**Definition 7.2.** *For the  $n$ -Kronecker quiver we call the largest Gabriel-Roiter measure in the central part the  $\mathcal{F}_n$ -Gabriel-Roiter measure. For any quiver  $Q$  we propose to call the largest Gabriel-Roiter measure in the central part the  $\mathcal{F}_Q$ -Gabriel-Roiter measure. In some sense this is the full Gabriel-Roiter measure in the central part, i.e., there is no larger measure (in the sense of the Gabriel-Roiter measure) starting denser than the  $\mathcal{F}_Q$ -Gabriel-Roiter measure.*

## 8 A partition formula for Fibonacci numbers

We are going to present a partition formula for the odd index Fibonacci numbers. These Fibonacci numbers appear in the dimension vectors of a 2-parameter family of indecomposable regular representations (i.e., those having Tits form  $-1$ ) of the 3-Kronecker quiver. The even index Fibonacci numbers have been dealt with in a recent paper [FR], looking at the exceptional representations of the 3-Kronecker quiver and we will proceed similar to the methods in [FR].

Let  $f_0, f_1, \dots$  be the Fibonacci numbers, with  $f_0 = 0, f_1 = 1$  and  $f_{i+1} = f_i + f_{i-1}$  for  $i \geq 1$ . The odd index Fibonacci numbers  $f_{2n+1}$  are the numbers in the sequence

$$1, 2, 5, 13, 34, 89, 233, 610, 1597, \dots,$$

which is a subset of the Fibonacci sequence, which begins:

$$0, 1, 1, 2, 3, 5, 8, 13, 21, 34, 55, 89, 144, 233, 377, 610, 987, 1597, 2584, 4181, \dots$$

As in section 2.3, we will make use of the 3-regular tree.<sup>13</sup> This is just the universal covering of the 3-Kronecker quiver.<sup>14</sup>

Recall that the quiver  $Q$  may be considered as the universal covering of the quiver  $\overline{Q}$ . Any representation  $V$  of  $Q$  gives rise to a representation  $\overline{V}$  of  $\overline{Q}$  (by attaching to the vertex 0 of  $\overline{Q}$  the direct sum of the vector spaces attached to the various sinks of  $Q$ , and attaching to 1 the direct sum of the vector spaces attached to the sources). The representations of  $\overline{Q}$  obtained in this way are those which are gradable by the free (non-abelian) group in 3 free generators. The quivers which are of interest in our case are, on the one hand, the 3-Kronecker quiver  $\overline{Q}$  (with two vertices, say labelled 1 and 2, and three arrows  $2 \rightarrow 1$ ) and, on the other hand, the bipartite quiver  $Q$  whose underlying graph (obtained by deleting the orientation of the arrows) is the 3-regular tree. As already mentioned in section 2.3, it is important to note that the covering functor  $V \mapsto \overline{V}$  preserves indecomposability and satisfies  $\mathbf{dim} \overline{V} = \mathbf{dim} V$ .

Let us thus start with the 3-regular tree  $(T, E)$  with vertex set  $T$  and edge set  $E$ . Fix a vertex  $x_0$  as base point. Let  $T_r$  be the sets of vertices of  $T$  which have distance  $r$  to  $x_0$ , thus  $T_0 = \{x_0\}$ ,  $T_1$  are the neighbours of  $x_0$ , and so on. The vertices in  $T_r$  will be called even or odd, depending on  $r$  being even or odd. Note that  $|T_0| = 1$  and we have:

**Lemma 8.1.**  $|T_r| = 3 \cdot 2^{r-1}$  for  $r \geq 1$

<sup>13</sup>It is also called the 3-Cayley tree without leaves, and a Bruhat-Tits tree. M. Baake pointed out, that this is also known as the *Bethe lattice* with coordination number 3 in the theory of exactly solvable models.

<sup>14</sup>Diane Castonguay and J. A. de la Peña have already made use of this useful fact in a different context in the paper *On the inductive construction of Galois coverings of algebras*, Journal of Algebra 263, 2003, 59-74.

*Proof.* For the proof we use induction:  $T_1$  consists of the three neighbours of  $x_0$ . For  $r \geq 1$ , any element in  $T_r$  has precisely one neighbour in  $T_{r-1}$ , thus two neighbours in  $T_{r+1}$ , therefore  $|T_{r+1}| = 2|T_r|$ .  $\square$

Given a set  $S$ , let  $\mathbb{Z}[S]$  be the set of functions  $S \rightarrow \mathbb{Z}$  with finite support. This is the free abelian group on  $S$  (or better, on the set of functions with support being an element of  $S$  such that the only non-zero value is 1).

We are interested in certain elements  $a_t \in \mathbb{Z}[T]$ . Any vertex  $y \in T$  yields a reflection  $\sigma_y$  on  $\mathbb{Z}[T]$ , defined for  $b \in \mathbb{Z}[T]$  by

$$(\sigma_y b)(x) = \begin{cases} b(x) & x \neq y \\ -b(y) + \sum_{z \in N(y)} b(z) & x = y, \end{cases} \quad \text{provided}$$

where  $N(y)$  denotes the set of neighbours of  $y$  in  $(T, E)$ . (This is just the reflection process as described in section 1.5.)

Denote by  $\Phi_0$  the product of the reflections  $\sigma_y$  with  $y$  even. This product is independent of the order, since these reflections commute: even vertices never are neighbours of each other. Similarly, we denote by  $\Phi_1$  the product of the reflections  $\sigma_y$  with  $y$  odd.

The elements of  $\mathbb{Z}[T]$  we are interested in, are labelled  $a_t$  with  $t \in \mathbb{N}_0$ .

We will start a reflection process at the representation  $R[1]_I$ , with  $I = \{1\}$ . Recall that as a coefficient quiver one may picture this representation with dimension vector  $\begin{pmatrix} 2 \\ 1 \end{pmatrix}$  as follows:

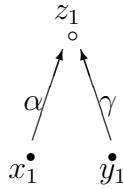

This is an indecomposable representation in the universal covering of the 3-Kronecker quiver: when drawing it into the 3-regular tree, we can set the vertex  $x_0$  on  $T_0$  and on  $T_1$  we have two vertices which are connected to  $x_0$  and one which is not. Since each basis vector spans a 1-dimensional  $k$ -space, the two vertices in the 3-regular tree carry the value 1:

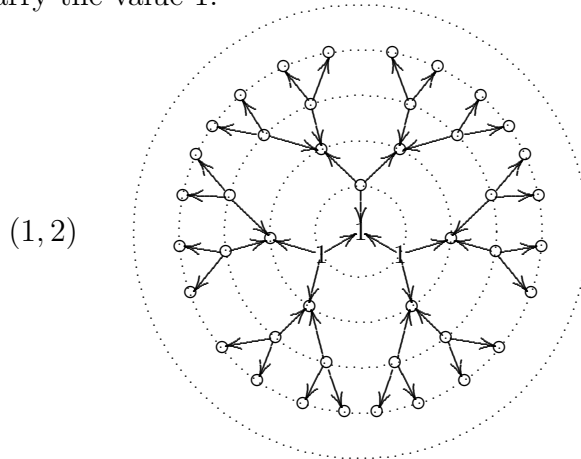

In the pictures,  $(T, E)$  has been endowed with an orientation such that the edges point to the even vertices. In this way, the even vertices are sinks, the odd vertices are sources. The dotted circles indicate the various sets  $T_r$ , the center is just  $T_0 = \{x_0\}$ .

Now use the characteristic function  $a_t$ , setting for  $T_0$ ,  $a_0(x) = 0$  unless  $x = x_0$  and  $a_0(x_0) = 1$ . For  $T_1$ ,  $a_0(x) = 0$  unless  $x = x_0$  and  $a_0(x_0) = 1$  and for the two vertices  $x_1$  on  $T_1$ , which are connected to  $x_0$ ,  $a_0(x_1) = 1$ . Consider  $a_t = (\Phi_0 \Phi_1)^t a_0$ , with  $t \geq 0$ .

Now define two functions  $a[r]_t, a'[r]_t : \mathbb{N}_0 \rightarrow \mathbb{Z}$  for any  $r \geq 0$ , by letting

$$a[r]_t = a_t(x) \quad \text{if } r \in \mathbb{N}_0 \text{ and } x \in T_r, x \text{ is connected to a neighbour,}$$

$$a'[r]_t = a_t(x) \quad \text{if } r \in \mathbb{N}_0 \text{ and } x \in T_r, x \text{ is not connected to a neighbour.}$$

We then have the following partition formula for the odd index Fibonacci numbers.

$$f_{4t+1} = \sum_{r \text{ odd}} \frac{2|T_r|}{3} \cdot a[r]_t + \sum_{r \text{ odd}} \frac{|T_r|}{3} \cdot a'[r]_t = 2 \sum_{m \geq 0} 2^{2m-1} \cdot a[2m]_t + \sum_{m \geq 0} 2^{2m-1} \cdot a'[2m]_t,$$

$$f_{4t+3} = \sum_{r \text{ even}} \frac{2|T_r|}{3} \cdot a[r]_t + \sum_{r \text{ even}} \frac{|T_r|}{3} \cdot a'[r]_t = a[0]_t + 2 \sum_{m \geq 1} 2^{2m} \cdot a[2m+1]_t + \sum_{m \geq 1} 2^{2m} \cdot a'[2m+1]_t.$$

Note that we have used above lemma and so  $|T_r|$  is divisible by 3 for any  $r$ . The sums exhibited are finite sums, since  $a[r]_t = 0$  and  $a'[r]_t = 0$  for  $r > 2t$ . (Since we are dealing with the representation over the universal covering, one can just take the sums over the even and odd circles  $T_r$ .) For example, we obtain the following two equalities for the pair of numbers (34, 89):

$$\begin{aligned} 34 = f_9 &= 1 \cdot 4 + 2 \cdot 1 + 4 \cdot 3 + 16 \cdot 1 \\ 89 = f_{11} &= 1 \cdot 5 + 2 \cdot 8 + 4 \cdot 1 + 8 \cdot 4 + 32 \cdot 1. \end{aligned}$$

When doing the reflection process in the universal covering one just reflects at each sink or source and gets a new indecomposable representation, hence an indecomposable representation for the 3-Kronecker quiver. Look again at  $R[1]_I$ , with  $I = \{1\}$ . The first reflection gives a representation of dimension vector  $\begin{pmatrix} 2 \\ 5 \end{pmatrix}$ :

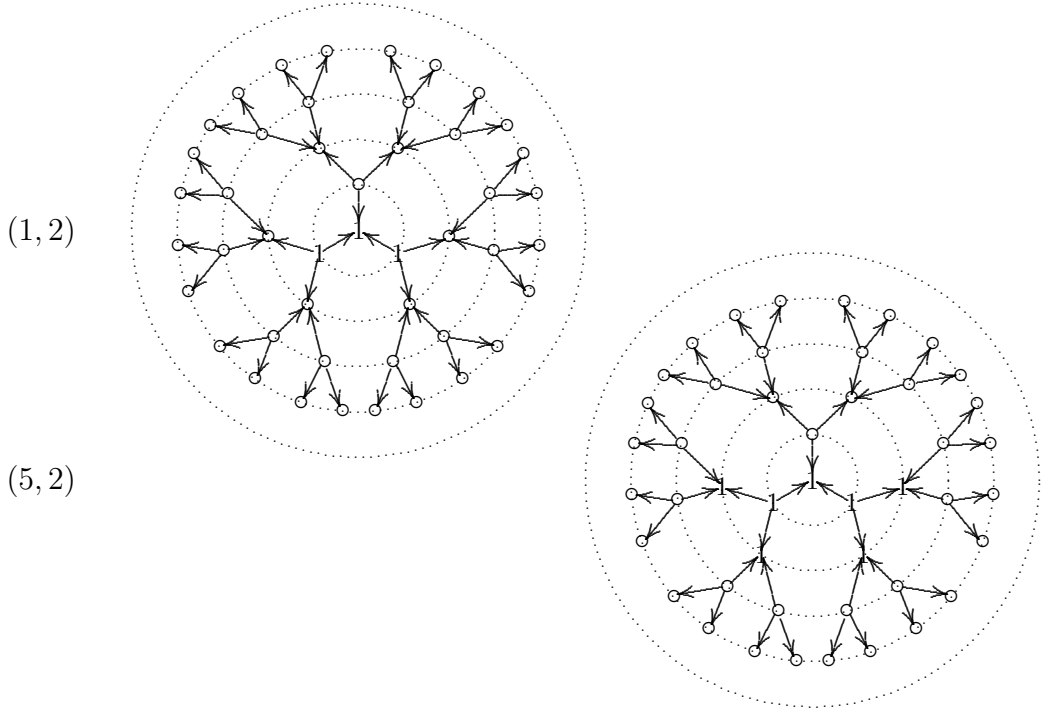

Of course, the interest in the odd index Fibonacci numbers comes from the fact that the pairs  $[f_{4t+1}, f_{4t+3}]$  provide the dimension vectors of the indecomposable regular representations of the 3-Kronecker quiver with Tits form of value  $-1$ . For more details and the proof in the even index case we refer to [FR].

Here is a table displaying some entries used in the sum partition for odd index Fibonacci numbers:

$a[0]_t$	$a[1]_t, a'[1]_t$	$a[2]_t, a'[2]_t$	$a[3]_t, a'[3]_t$	$a[4]_t, a'[4]_t$	$a[5]_t, a'[5]_t$	$a[6]_t, a'[6]_t$	$(f_{4t+1}, f_{4t+3})$
1	1,0						(1,2)
1	1,0	1,0					(5,2)
1	2,1	1,0	1,0				(5,13)
4	2,1	3,1	1,0	1,0			(13,34)
4	8,5	3,1	4,1	1,0	1,0		(34,89)
17	8,5	13,6	4,1	5,1	1,0	1,0	(89,233)

Table 2: Entries in sum partitions of odd index Fibonacci numbers.

Let us prove the partition formula given above:

We consider the multigraph  $(\overline{T}, \overline{E})$  with two vertices 0, 1 and three edges between 0 and 1.



Any element  $c \in \mathbb{Z}[\overline{T}]$  is determined by the values  $c(0)$  and  $c(1)$ , thus we will

write  $c = [c(0), c(1)]$ . We define

$$\begin{aligned}\bar{a}_t(0) &= \sum_{r \text{ even}} \frac{2|T_r|}{3} \cdot a[r]_t + \sum_{r \text{ even}} \frac{|T_r|}{3} \cdot a'[r]_t, \\ &= a[0]_t + 2 \sum_{m \geq 1} 2^{2m} \cdot a[2m+1]_t + \sum_{m \geq 1} 2^{2m} \cdot a'[2m+1]_t, \\ \bar{a}_t(1) &= \sum_{r \text{ odd}} \frac{2|T_r|}{3} \cdot a[r]_t + \sum_{r \text{ odd}} \frac{|T_r|}{3} \cdot a'[r]_t \\ &= 2 \sum_{m \geq 0} 2^{2m-1} \cdot a[2m]_t + \sum_{m \geq 0} 2^{2m-1} \cdot a'[2m]_t,\end{aligned}$$

and have to show:  $[\bar{a}_t(0), \bar{a}_t(1)] = [f_{4t+3}, f_{4t+1}]$ . The claim is true for  $t = 1$ , since

$$[\bar{a}_0(0), \bar{a}_0(1)] = [2, 1] = [f_3, f_1].$$

The general assertion will follow from the following recursion formulae

$$\begin{aligned}[\bar{a}_t(0), \bar{a}_t(1)] \begin{bmatrix} 8 & 3 \\ -3 & -1 \end{bmatrix} &= [\bar{a}_{t+1}(0), \bar{a}_{t+1}(1)], \\ [f_{m+3}, f_{m+1}] \begin{bmatrix} 8 & 3 \\ -3 & -1 \end{bmatrix} &= [f_{m+7}, f_{m+5}].\end{aligned}$$

For the Fibonacci numbers, this is well-known:

$$\begin{aligned}[f_{m+7}, f_{m+5}] &= [f_{m+7}, f_{m+5}] \begin{bmatrix} 1 & 0 \\ 1 & 1 \end{bmatrix} = [f_{m+2}, f_{m+1}] \begin{bmatrix} 1 & 1 \\ 1 & 0 \end{bmatrix}^4 \begin{bmatrix} 1 & 0 \\ 1 & 1 \end{bmatrix} \\ &= [f_{m+3}, f_{m+1}] \begin{bmatrix} 1 & 0 \\ 1 & 1 \end{bmatrix}^{-1} \begin{bmatrix} 1 & 1 \\ 1 & 0 \end{bmatrix}^4 \begin{bmatrix} 1 & 0 \\ 1 & 1 \end{bmatrix}\end{aligned}$$

and the product of the matrices in the last line is just  $\begin{bmatrix} 8 & 3 \\ -3 & -1 \end{bmatrix}$ , which is the Coxeter transformation of the 3-Kronecker quiver, as seen in chapter 1.1.

It remains to deal with  $\bar{a}_t$ . We may consider  $(T, E)$  as the universal covering of  $(\bar{T}, \bar{E})$ , say with a covering map  $\pi : (T, E) \rightarrow (\bar{T}, \bar{E})$ , where  $\pi(x) = 0$  if  $x$  is an even vertex of  $(T, E)$ , and  $\pi(x) = 1$  if  $x$  is an odd vertex. Such a covering map will provide a bijection between the three edges in  $E$  which contain a given vertex  $x$  with the edges in  $\bar{E}$ .

Given  $b \in \mathbb{Z}[T]$ , define  $\bar{b} \in \mathbb{Z}[\bar{T}]$  by

$$\bar{b}(i) = \sum_{x \in \pi^{-1}(i)} b(x) \quad \text{for } i = 0, 1.$$

Observe that in this way we obtain from  $a_t \in \mathbb{Z}[T]$  precisely  $\bar{a}_t \in \mathbb{Z}[\bar{T}]$  as defined above.

On  $\mathbb{Z}[\bar{T}]$ , we also consider reflections, but we have to take into account the multiplicity of edges: There are the two reflections  $\sigma_0, \sigma_1$ , with

$$\begin{aligned}(\sigma_0 c)(0) &= -c(0) + 3c(1), & (\sigma_0 c)(1) &= c(1), \\ (\sigma_1 c)(0) &= c(0), & (\sigma_1 c)(1) &= -c(1) + 3c(0),\end{aligned}$$

for  $c \in \mathbb{Z}[\overline{T}]$ . Note that this implies that

$$[c(0), c(1)] \begin{bmatrix} 8 & 3 \\ -3 & -1 \end{bmatrix} = [(\sigma_0\sigma_1c)(0), (\sigma_0\sigma_1c)(1)].$$

We finish the proof by observing that  $\bar{a}_t = (\sigma_0\sigma_1)^t\bar{a}_0$ , which follows from the following equations: Let  $b \in \mathbb{Z}[T]$ , then

$$\overline{\Phi_0 b} = \sigma_0 \bar{b}, \quad \overline{\Phi_1 b} = \sigma_1 \bar{b}.$$

This finishes the proof.

On the following page we have pictured the reflection process on the 3-regular tree.<sup>15</sup> As before, in the pictures,  $(T, E)$  has been endowed with an orientation such that the edges point to the even vertices. In this way, the even vertices are sinks, the odd vertices are sources. The dotted circles indicate the various sets  $T_r$ , the center is just  $T_0 = \{x_0\}$ .

Finally note, that the considerations can be generalized to the  $n$ -regular tree and thus to the  $n$ -Kronecker quiver.

---

<sup>15</sup>I am grateful to C. M. Ringel for providing the  $\text{\LaTeX}$  code of these pictures.

(1, 2)

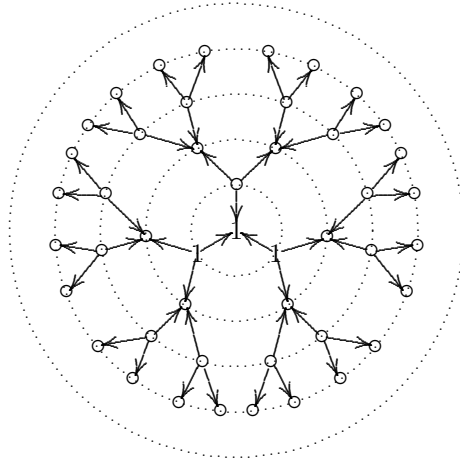

(5, 2)

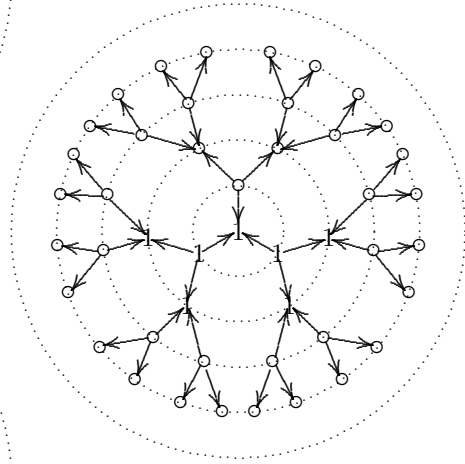

(5, 13)

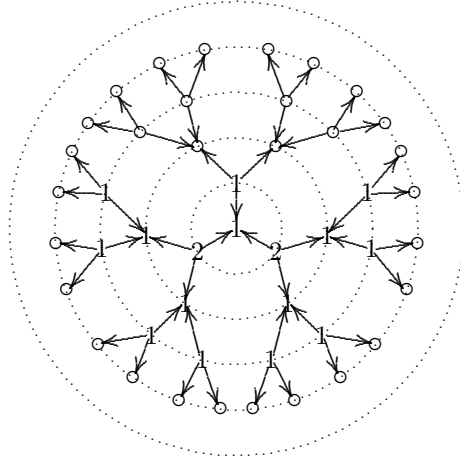

(13, 34)

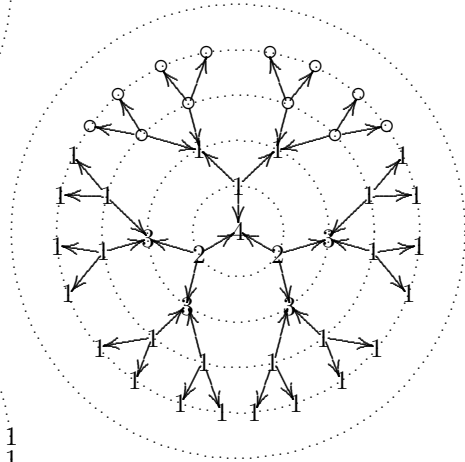

(34, 89)

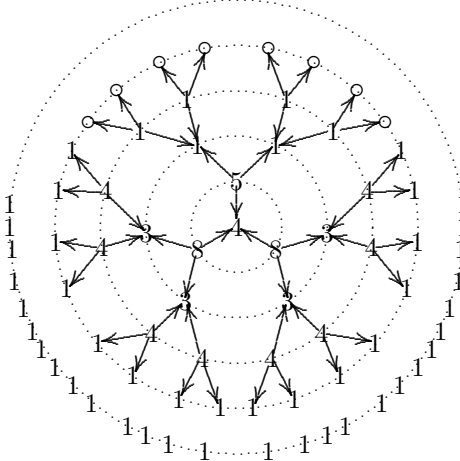

## 9 Morphisms between regular modules

Let  $A$  be a wild hereditary algebra. Recall that a representation is called *regular* provided it is neither preprojective nor preinjective. If  $M$  is a regular representation, then it is not uniquely determined by its dimension vector. Instead, for any regular dimension vector there are infinitely many regular representations, and each representation depends on the three maps  $\alpha, \beta, \gamma$  in the case of the 3-Kronecker quiver.

**Definition 9.1.** *Let  $\mathcal{C}$  be a regular component of the Auslander-Reiten quiver. An indecomposable  $A$ -module  $M \in \mathcal{C}$  is called quasi-simple, if the Auslander-Reiten sequence  $0 \rightarrow \tau M \rightarrow E \rightarrow M \rightarrow 0$  has indecomposable middle term  $E$ .*

Note that if  $M$  has minimal  $k$ -dimension among all indecomposable modules in  $\mathcal{C}$ , then  $M$  and hence all  $\tau^m M$  are quasi-simple.

For  $M$  quasi-simple in  $\mathcal{C}$ , there is an infinite chain of irreducible monomorphisms, respectively epimorphisms:

$$\begin{aligned} M &= M(1) \rightarrow M(2) \rightarrow M(3) \rightarrow \dots \rightarrow M(n) \rightarrow \dots, \\ \dots &\rightarrow [m]M \rightarrow [m-1]M \rightarrow \dots \rightarrow [2]M \rightarrow [1]M = M. \end{aligned}$$

For  $X=M(i)$ , we call  $i$  the *quasi-length* of  $X$ , and  $M$  the *quasi-socle* of  $X$ . Similarly for  $Y=[i]M$ , we call  $i$  the *quasi-length* of  $Y$ , and  $M$  its *quasi-top*. We have:  $\tau^m M(i) = (\tau^m M)(i)$  and  $\tau^m [i]M = [i](\tau^m M)$  for all  $m \in \mathbb{Z}$ . Any regular module is uniquely determined by its quasi-length and quasi-socle, resp. quasi-top.

Let  $M$  be quasi-simple in  $\mathcal{C}$  and let  $M = M(1) \rightarrow M(2) \rightarrow M(3) \rightarrow \dots \rightarrow M(n) \rightarrow \dots$  be a chain of irreducible monomorphisms. We may fix these irreducible maps and consider them as inclusions. All the modules  $\tau^i M$  are pairwise non-isomorphic, hence all the modules  $\tau^i M(m)$  are pairwise non-isomorphic.

**Theorem 9.1.** *If  $X$  is an indecomposable  $A$ -module in  $\mathcal{C}$ , then  $X \cong \tau^m M(i)$  for some  $m, i$ . So  $\mathcal{C}$  is of the form  $\mathbb{Z}A_\infty$ .*

The following theorem is due to Yingbo Zhang<sup>16</sup>:

**Theorem 9.2.** *Let  $A$  be a connected wild hereditary algebra and  $\mathcal{C}$  be a regular component of the Auslander-Reiten quiver. If  $M, N$  are indecomposable modules in  $\mathcal{C}$  with  $M \not\cong N$ , then  $\mathbf{dim} M \neq \mathbf{dim} N$ .*

A theorem of O. Kerner [K2] says:

**Theorem 9.3.** *Let  $A$  be a connected wild hereditary algebra,  $X, Y$  non-zero regular  $A$ -modules. Then for  $m$  sufficiently large, we have  $\mathrm{Hom}_A(X, \tau^m Y) \neq 0$ .*

<sup>16</sup>See *The modules in any component of the AR-quiver of a wild hereditary artin algebra are uniquely determined by their composition factors.* Archiv Math. 53, 1989, 250-251.

This implies that there are non-zero maps between any two regular components if  $A$  is connected wild hereditary. Recall that in the tame case, all regular components (tubes) are pairwise orthogonal.

We also know that if  $A$  is a connected tame hereditary algebra,  $X$  a preprojective and  $Y$  a preinjective module, and  $\mathcal{T}$  any regular tube, then each homomorphism  $f : X \rightarrow Y$  factorises through  $\text{add}(\mathcal{T})$ . For wild hereditary algebras a much stronger factorisation property holds, due to O. Kerner ([K2]):

**Theorem 9.4.** *Let  $A = kQ$  be a finite-dimensional connected wild hereditary algebra,  $X_1 \neq 0$  a preprojective,  $X_2$  a regular and  $X_3$  a preinjective module. If  $R \neq 0$  is regular, then we have:*

- (a) *Each homomorphism  $f : X_1 \rightarrow X_2$  factorises through  $\tau^{-m}R$  for  $m \gg 0$ .*
- (b) *Each homomorphism  $g : X_2 \rightarrow X_3$  factorises through  $\tau^m R$  for  $m \gg 0$ .*
- (c) *Each homomorphism  $h : X_1 \rightarrow X_3$  factorises through  $\tau^m R$  for  $|m| \gg 0$ , and also*
- (a') *There exists a monomorphism  $X_1 \rightarrow \tau^m X_2$  for  $|m| \gg 0$ .*
- (b') *There exists a monomorphism  $X_i \rightarrow \tau^m X_3$  for  $m \gg 0$  and  $i = 1, 2$ .*

## 9.1 Elementary modules

**Definition 9.2.** *A regular  $A$ -module  $E \neq 0$  is called elementary if there is no short exact sequence  $0 \rightarrow U \rightarrow E \rightarrow V \rightarrow 0$  with  $U, V$  both non-zero regular  $A$ -modules.*

It follows that if  $E$  is elementary, all the modules  $\tau^i E$ ,  $i \in \mathbb{Z}$  are elementary. Note that for tame hereditary algebras the elementary modules are just the quasi-simple regular modules. One can show that each non-zero regular module  $M$  has a filtration:

$$0 = M_{r+1} \subset M_r \subset \dots \subset M_1 \subset M_0 = M$$

with  $M_i/M_{i+1}$  elementary for  $i = 0, \dots, r$ . Since the Auslander-Reiten translate  $\tau$  is exact and an equivalence on  $A\text{-reg}$ , for any  $m \in \mathbb{Z}$ , the module  $\tau^m M$  has a filtration:

$$0 = \tau^m M_{r+1} \subset \tau^m M_r \subset \dots \subset \tau^m M_1 \subset \tau^m M_0 = \tau^m M$$

with  $\tau^m M_i/\tau^m M_{i+1} \cong \tau^m(M_i/M_{i+1})$  elementary for  $i = 0, \dots, r$ . One can show that every elementary module is a brick (i.e. its endomorphism ring is just  $k$ ).

In the case of the 3-Kronecker quiver, the modules having dimension vector  $(1, 1)$ ,  $(1, 2)$  and the modules in their Coxeter orbits are elementary modules. We have  $(2, 1) = (1, 2)\Phi^{-1}$ , and the Coxeter orbits are:

$$\dots (13, 34), (2, 5), (1, 1), (5, 2), (34, 13) \dots \text{ and}$$

... (34, 89), (5, 13), (1, 2), (2, 1), (13, 5), (89, 34) ...

respectively.

It is not known how many Coxeter orbits of dimension vectors of elementary modules exist for this quiver. However, by a result of F. Lukas ([L2]) this number has to be finite.

*Remark.* As short exact sequences with elementary modules of length  $\leq 3$  as middle term, one only gets the following:

$$\begin{aligned} 0 \rightarrow (1, 0) \rightarrow (1, 1) \rightarrow (0, 1) \rightarrow 0 \\ 0 \rightarrow (1, 1) \rightarrow (1, 2) \rightarrow (0, 1) \rightarrow 0 \\ 0 \rightarrow (1, 0) \rightarrow (2, 1) \rightarrow (1, 1) \rightarrow 0 \end{aligned}$$

From [Ri8] we know that the wild algebra  $kK(3)$ , having two simple modules, has no regular stones (i.e. indecomposable modules being bricks without self-extensions). C.M. Ringel<sup>17</sup> has also shown, that for an algebra with more than two simple modules, there always exist regular stones. In our case, however, the preprojective and preinjective modules are the only stones.

## 9.2 Matrices

Let  $M$  be an indecomposable regular module over the 3-Kronecker quiver with Tits form  $q(\mathbf{dim} M) = -1$ . Let us calculate  $\tau M$  explicitly for different  $M$ . Beginning with the case  $M$  having dimension vector  $\mathbf{dim} M = \begin{pmatrix} 1 \\ 1 \end{pmatrix}$ , we consider the representations  $M_\alpha, M_\beta, M_\gamma$ , defined as follows:

$M_\alpha : \alpha = [1], \beta = [0], \gamma = [0]$ . Then the coefficient quiver looks as follows: 

We have  $\dim \text{End}(M_\alpha) = 1$ , and since the simple projective module with dimension vector  $\begin{pmatrix} 0 \\ 1 \end{pmatrix}$  is the only indecomposable submodule,  $M_\alpha$  has Gabriel-Roiter measure  $\{1, 2\}$ .

Applying  $\tau$  one gets the representation  $\tau M_\alpha$ , with the following properties:  $\mathbf{dim} \tau M_\alpha = \begin{pmatrix} 5 \\ 2 \end{pmatrix}$ ,  $q(\mathbf{dim} \tau M_\alpha) = -1$ ,  $\dim \text{End}(\tau M_\alpha) = 1$ , and

$$\alpha = \begin{bmatrix} 1 & 0 & 0 & 0 & 0 \\ 0 & 1 & 0 & 0 & 0 \end{bmatrix}, \beta = \begin{bmatrix} 0 & 0 & 0 & 0 & -1 \\ 0 & 0 & 1 & 0 & 0 \end{bmatrix}, \gamma = \begin{bmatrix} 0 & 0 & 0 & 1 & 0 \\ 0 & 0 & 0 & 0 & 1 \end{bmatrix}.$$

A coefficient quiver can be drawn as:

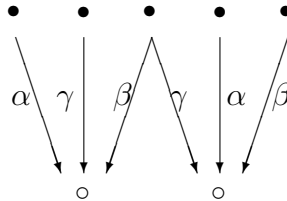

<sup>17</sup>In *The regular components of the Auslander-Reiten quiver of a tilted algebra*. Chinese Ann. Math. B. 9 (1988), 1-18.

$M_\beta : \alpha = [0], \beta = [1], \gamma = [0]$ . Then the coefficient quiver looks as follows:  $\downarrow$

We also have  $\dim \text{End}(M_\beta) = 1$ , and since the simple projective module with dimension vector  $\begin{pmatrix} 0 \\ 1 \end{pmatrix}$  is the only indecomposable submodule,  $M_\beta$  has Gabriel-Roiter measure  $\{1, 2\}$ .

Applying  $\tau$  one gets the representation  $\tau M_\beta$ , with the following properties:  $\mathbf{dim} \tau M_\beta = \begin{pmatrix} 5 \\ 2 \end{pmatrix}$ ,  $q(\mathbf{dim} \tau M_\beta) = -1$ ,  $\dim \text{End}(\tau M_\beta) = 1$ , and

$$\alpha = \begin{bmatrix} 0 & 0 & 0 & 0 & -1 \\ 1 & 0 & 0 & 0 & 0 \end{bmatrix}, \beta = \begin{bmatrix} 0 & 1 & 0 & 0 & 0 \\ 0 & 0 & 1 & 0 & 0 \end{bmatrix}, \gamma = \begin{bmatrix} 0 & 0 & 0 & 1 & 0 \\ 0 & 0 & 0 & 0 & 1 \end{bmatrix}.$$

A coefficient quiver can be drawn as:

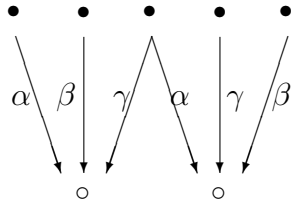

$M_\gamma : \alpha = [0], \beta = [0], \gamma = [1]$ . Then the coefficient quiver looks as follows:  $\swarrow$

We also have  $\dim \text{End}(M_\gamma) = 1$ , and since the simple projective module with dimension vector  $\begin{pmatrix} 0 \\ 1 \end{pmatrix}$  is the only indecomposable submodule,  $M_\gamma$  has Gabriel-Roiter measure  $\{1, 2\}$ .

Applying  $\tau$  one gets the representation  $\tau M_\gamma$ , with the following properties:  $\mathbf{dim} \tau M_\gamma = \begin{pmatrix} 5 \\ 2 \end{pmatrix}$ ,  $q(\mathbf{dim} \tau M_\gamma) = -1$ ,  $\dim \text{End}(\tau M_\gamma) = 1$ , and

$$\alpha = \begin{bmatrix} 0 & 0 & -1 & 0 & 0 \\ 1 & 0 & 0 & 0 & 0 \end{bmatrix}, \beta = \begin{bmatrix} 0 & 1 & 0 & 0 & 0 \\ 0 & 0 & 1 & 0 & 0 \end{bmatrix}, \gamma = \begin{bmatrix} 0 & 0 & 0 & 1 & 0 \\ 0 & 0 & 0 & 0 & 1 \end{bmatrix}.$$

A coefficient quiver can be drawn as:

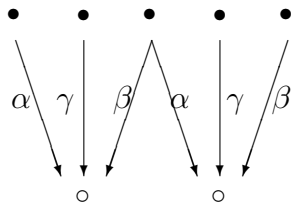

*Remark.* Note that in this situation, when  $M$  is a tree module, then  $\tau M$  remains a tree module. This fact is unfortunately not true in general.

In the case when  $N$  is an indecomposable regular module over the 3-Kronecker quiver with Tits form  $q(\mathbf{dim} N) = -1$  with dimension vector  $\mathbf{dim} N = \begin{pmatrix} 2 \\ 1 \end{pmatrix}$ , we get three possible choices which of the arrows  $\alpha, \beta, \gamma$  we set to be the zero map. This gives the three representations  $N_{\alpha\beta}, N_{\alpha\gamma}, N_{\beta\gamma}$ :

$N_{\alpha\beta} : \alpha = [1, 0], \beta = [0, 1], \gamma = [0, 0]$ . A coefficient quiver is:

We have  $\dim \text{End}(N_{\alpha\beta}) = 1$ , and two indecomposable submodules  $M_\alpha$  and  $M_\beta$ , which are non-isomorphic Gabriel-Roiter submodules. So  $N_{\alpha\beta}$  has Gabriel-Roiter measure  $\{1, 2, 3\}$ .

Applying  $\tau$  one gets the representation  $\tau N_{\alpha\beta}$ , with the following properties:  $\mathbf{dim} \tau N_{\alpha\beta} = \binom{13}{5}$ ,  $q(\mathbf{dim} \tau N_{\alpha\beta}) = -1$ ,  $\dim \text{End}(\tau N_{\alpha\beta}) = 1$ , and

$$\alpha = \begin{bmatrix} 0 & 0 & 0 & 0 & 0 & -1 & 0 & 0 & 0 & 0 & 0 & 0 & -1 \\ 1 & 0 & 0 & 0 & 0 & 0 & 0 & 0 & 0 & 0 & 0 & 0 & 0 \\ 0 & 0 & 0 & 0 & 1 & 0 & 0 & 0 & 0 & 0 & 0 & 1 & 0 \\ 0 & 1 & 0 & 0 & 0 & 0 & 0 & 0 & 0 & 0 & 0 & 0 & 0 \\ 0 & 0 & 1 & 0 & 0 & 0 & 0 & 0 & 0 & 0 & 0 & 0 & 0 \end{bmatrix},$$

$$\beta = \begin{bmatrix} 0 & 0 & 0 & 1 & 0 & 0 & 0 & 0 & 0 & 0 & 0 & 0 & 0 \\ 0 & 0 & 0 & 0 & 1 & 0 & 0 & 0 & 0 & 0 & 0 & 0 & 0 \\ 0 & 0 & 0 & 0 & 0 & 1 & 0 & 0 & 0 & 0 & 0 & 0 & 0 \\ 0 & 0 & 0 & 0 & 0 & 0 & 1 & 0 & 0 & 0 & 0 & 0 & 0 \\ 0 & 0 & 0 & 0 & 0 & 0 & 0 & 1 & 0 & 0 & 0 & 0 & 0 \end{bmatrix},$$

$$\gamma = \begin{bmatrix} 0 & 0 & 0 & 0 & 0 & 0 & 0 & 0 & 1 & 0 & 0 & 0 & 0 \\ 0 & 0 & 0 & 0 & 0 & 0 & 0 & 0 & 0 & 1 & 0 & 0 & 0 \\ 0 & 0 & 0 & 0 & 0 & 0 & 0 & 0 & 0 & 0 & 1 & 0 & 0 \\ 0 & 0 & 0 & 0 & 0 & 0 & 0 & 0 & 0 & 0 & 0 & 1 & 0 \\ 0 & 0 & 0 & 0 & 0 & 0 & 0 & 0 & 0 & 0 & 0 & 0 & 1 \end{bmatrix}.$$

Drawn as a tree one gets a coefficient quiver pictured in figure 4.<sup>18</sup>

$N_{\alpha\gamma} : \alpha = [1, 0], \beta = [0, 0], \gamma = [0, 1]$ . A coefficient quiver is:

We have  $\dim \text{End}(N_{\alpha\gamma}) = 1$ , and two indecomposable submodules  $M_\alpha$  and  $M_\gamma$ , which are non-isomorphic Gabriel-Roiter submodules. So  $N_{\alpha\gamma}$  has Gabriel-Roiter measure  $\{1, 2, 3\}$ .

Applying  $\tau$  one gets the representation  $\tau N_{\alpha\gamma}$ , with the following properties:  $\mathbf{dim} \tau N_{\alpha\gamma} = \binom{13}{5}$ ,  $q(\mathbf{dim} \tau N_{\alpha\gamma}) = -1$ ,  $\dim \text{End}(\tau N_{\alpha\gamma}) = 1$ , and

$$\alpha = \begin{bmatrix} 0 & 0 & 0 & 0 & 0 & -1 & 0 & 0 & 0 & 0 & 0 & 0 & -1 \\ 1 & 0 & 0 & 0 & 0 & 0 & 0 & 0 & 0 & 0 & 0 & 0 & 0 \\ 0 & 1 & 0 & 0 & 0 & 0 & 0 & 0 & 0 & 0 & 0 & 0 & 0 \\ 0 & 0 & 1 & 0 & 0 & 0 & 0 & 0 & 0 & 0 & 0 & 0 & 0 \\ 0 & 0 & 0 & 0 & 1 & 0 & 0 & 0 & 0 & 0 & 0 & 1 & 0 \end{bmatrix},$$

<sup>18</sup>These pictures have been plotted using Maple and the program as in appendix A.2.

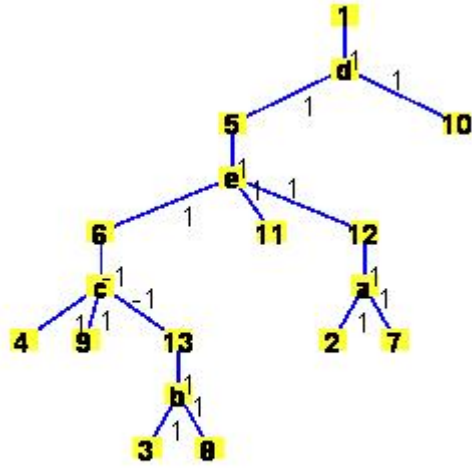

Figure 4: The module  $\tau N_{\alpha\beta}$  is a tree.

$$\beta = \begin{bmatrix} 0 & 0 & 0 & 1 & 0 & 0 & 0 & 0 & 0 & 0 & 0 & 0 & 0 \\ 0 & 0 & 0 & 0 & 1 & 0 & 0 & 0 & 0 & 0 & 0 & 0 & 0 \\ 0 & 0 & 0 & 0 & 0 & 1 & 0 & 0 & 0 & 0 & 0 & 0 & 0 \\ 0 & 0 & 0 & 0 & 0 & 0 & 1 & 0 & 0 & 0 & 0 & 0 & 0 \\ 0 & 0 & 0 & 0 & 0 & 0 & 0 & 1 & 0 & 0 & 0 & 0 & 0 \end{bmatrix},$$

$$\gamma = \begin{bmatrix} 0 & 0 & 0 & 0 & 0 & 0 & 0 & 0 & 0 & 1 & 0 & 0 & 0 \\ 0 & 0 & 0 & 0 & 0 & 0 & 0 & 0 & 0 & 0 & 1 & 0 & 0 \\ 0 & 0 & 0 & 0 & 0 & 0 & 0 & 0 & 0 & 0 & 0 & 1 & 0 \\ 0 & 0 & 0 & 0 & 0 & 0 & 0 & 0 & 0 & 0 & 0 & 0 & 1 \\ 0 & 0 & 0 & 0 & 0 & 0 & 0 & 0 & 0 & 0 & 0 & 0 & 1 \end{bmatrix}.$$

Drawn as a tree one gets a coefficient quiver pictured in figure 5.

$N_{\beta\gamma} : \alpha = [0, 0], \beta = [1, 0], \gamma = [0, 1]$ . A coefficient quiver is:  $\begin{array}{c} \vdots \\ \downarrow \\ \downarrow \end{array}$

We have  $\dim \text{End}(N_{\beta\gamma}) = 1$ , and two indecomposable submodules  $M_\beta$  and  $M_\gamma$ , which are non-isomorphic Gabriel-Roiter submodules. So  $N_{\beta\gamma}$  has Gabriel-Roiter measure  $\{1, 2, 3\}$ .

Applying  $\tau$  one gets the representation  $\tau N_{\beta\gamma}$ , with the following properties:

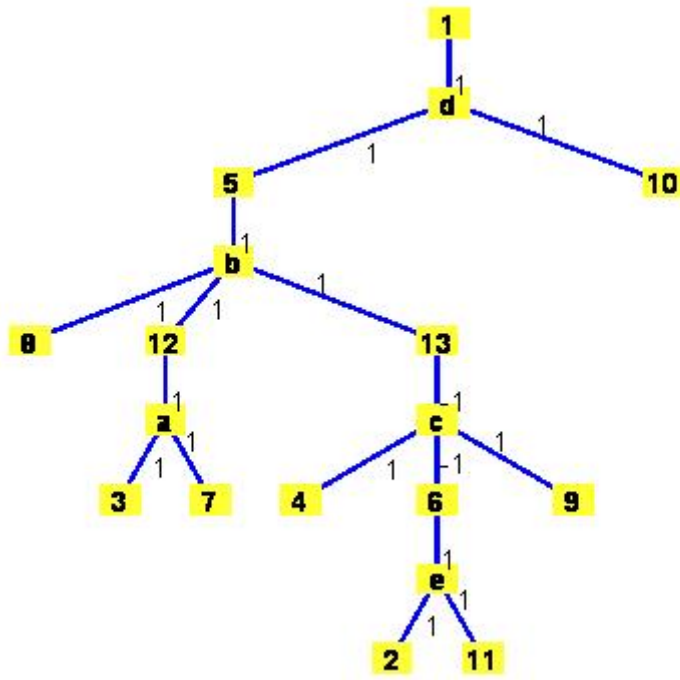

Figure 5: The module  $\tau N_{\alpha\gamma}$  is a tree.

$\mathbf{dim} \tau N_{\beta\gamma} = \binom{13}{5}$ ,  $q(\mathbf{dim} \tau N_{\beta\gamma}) = -1$ ,  $\dim \text{End}(\tau N_{\beta\gamma}) = 1$ , and

$$\alpha = \begin{bmatrix} 0 & 0 & 0 & 0 & 0 & 0 & 0 & 1 & 0 & 0 & 0 & -1 & 0 \\ 0 & 0 & 0 & 0 & 0 & -1 & 0 & 0 & 0 & 0 & 0 & 0 & -1 \\ 1 & 0 & 0 & 0 & 0 & 0 & 0 & 0 & 0 & 0 & 0 & 0 & 0 \\ 0 & 1 & 0 & 0 & 0 & 0 & 0 & 0 & 0 & 0 & 0 & 0 & 0 \\ 0 & 0 & 1 & 0 & 0 & 0 & 0 & 0 & 0 & 0 & 0 & 0 & 0 \end{bmatrix},$$

$$\beta = \begin{bmatrix} 0 & 0 & 0 & 1 & 0 & 0 & 0 & 0 & 0 & 0 & 0 & 0 & 0 \\ 0 & 0 & 0 & 0 & 1 & 0 & 0 & 0 & 0 & 0 & 0 & 0 & 0 \\ 0 & 0 & 0 & 0 & 0 & 1 & 0 & 0 & 0 & 0 & 0 & 0 & 0 \\ 0 & 0 & 0 & 0 & 0 & 0 & 1 & 0 & 0 & 0 & 0 & 0 & 0 \\ 0 & 0 & 0 & 0 & 0 & 0 & 0 & 1 & 0 & 0 & 0 & 0 & 0 \end{bmatrix},$$

$$\gamma = \begin{bmatrix} 0 & 0 & 0 & 0 & 0 & 0 & 0 & 0 & 1 & 0 & 0 & 0 & 0 \\ 0 & 0 & 0 & 0 & 0 & 0 & 0 & 0 & 0 & 1 & 0 & 0 & 0 \\ 0 & 0 & 0 & 0 & 0 & 0 & 0 & 0 & 0 & 0 & 1 & 0 & 0 \\ 0 & 0 & 0 & 0 & 0 & 0 & 0 & 0 & 0 & 0 & 0 & 1 & 0 \\ 0 & 0 & 0 & 0 & 0 & 0 & 0 & 0 & 0 & 0 & 0 & 0 & 1 \end{bmatrix}.$$

Drawn as a tree one gets a coefficient quiver as pictured in figure 6.

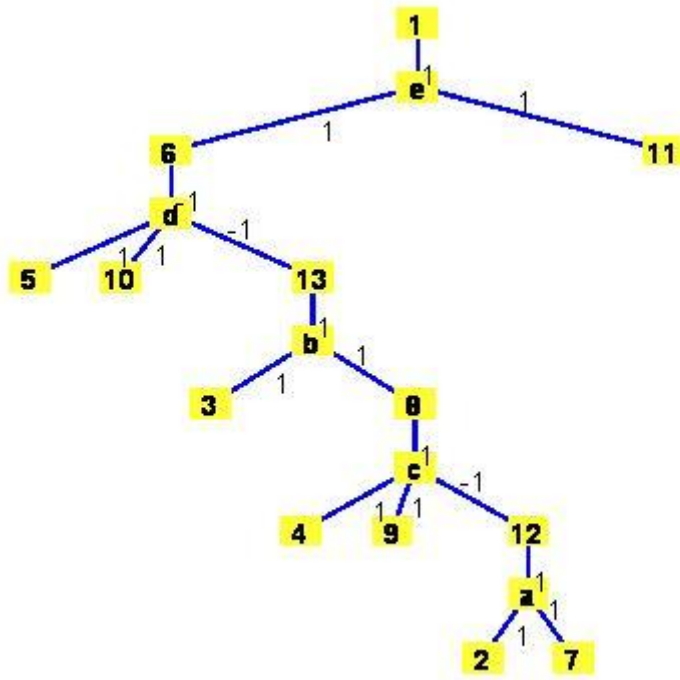

Figure 6: The module  $\tau N_{\beta\gamma}$  is a tree.

Let us now look at homomorphisms between these modules. We have:

- $\dim \text{Hom}(M_\alpha, N_{\alpha\beta}) = 1$ ,  $\dim \text{Hom}(M_\alpha, N_{\alpha\gamma}) = 1$ ,  $\dim \text{Hom}(M_\alpha, N_{\beta\gamma}) = 0$ ,  
 $\dim \text{Hom}(M_\alpha, \tau M_\alpha) = 2$ ,  $\dim \text{Hom}(M_\alpha, \tau M_\beta) = 1$ ,  $\dim \text{Hom}(M_\alpha, \tau M_\gamma) = 1$ ,  
 $\dim \text{Hom}(M_\alpha, \tau N_{\alpha\beta}) = 3$ ,  $\dim \text{Hom}(M_\alpha, \tau N_{\alpha\gamma}) = 3$ ,  $\dim \text{Hom}(M_\alpha, \tau N_{\beta\gamma}) = 3$ .
- $\dim \text{Hom}(M_\beta, N_{\alpha\beta}) = 1$ ,  $\dim \text{Hom}(M_\beta, N_{\alpha\gamma}) = 0$ ,  $\dim \text{Hom}(M_\beta, N_{\beta\gamma}) = 1$ ,  
 $\dim \text{Hom}(M_\beta, \tau M_\alpha) = 1$ ,  $\dim \text{Hom}(M_\beta, \tau M_\beta) = 2$ ,  $\dim \text{Hom}(M_\beta, \tau M_\gamma) = 1$ ,  
 $\dim \text{Hom}(M_\beta, \tau N_{\alpha\beta}) = 3$ ,  $\dim \text{Hom}(M_\beta, \tau N_{\alpha\gamma}) = 3$ ,  $\dim \text{Hom}(M_\beta, \tau N_{\beta\gamma}) = 3$ .
- $\dim \text{Hom}(M_\gamma, N_{\alpha\beta}) = 0$ ,  $\dim \text{Hom}(M_\gamma, N_{\alpha\gamma}) = 1$ ,  $\dim \text{Hom}(M_\gamma, N_{\beta\gamma}) = 1$ ,  
 $\dim \text{Hom}(M_\gamma, \tau M_\alpha) = 1$ ,  $\dim \text{Hom}(M_\gamma, \tau M_\beta) = 1$ ,  $\dim \text{Hom}(M_\gamma, \tau M_\gamma) = 2$ ,  
 $\dim \text{Hom}(M_\gamma, \tau N_{\alpha\beta}) = 3$ ,  $\dim \text{Hom}(M_\gamma, \tau N_{\alpha\gamma}) = 3$ ,  $\dim \text{Hom}(M_\gamma, \tau N_{\beta\gamma}) = 3$ .
- $\dim \text{Hom}(N_{\alpha\beta}, \tau M_\alpha) = 1$ ,  $\dim \text{Hom}(N_{\alpha\beta}, \tau M_\beta) = 1$ ,  $\dim \text{Hom}(N_{\alpha\beta}, \tau M_\gamma) = 0$ ,  
 $\dim \text{Hom}(N_{\alpha\beta}, \tau N_{\alpha\beta}) = 2$ ,  $\dim \text{Hom}(N_{\alpha\beta}, \tau N_{\alpha\gamma}) = 1$ ,  $\dim \text{Hom}(N_{\alpha\beta}, \tau N_{\beta\gamma}) = 1$ .
- $\dim \text{Hom}(N_{\alpha\gamma}, \tau M_\alpha) = 1$ ,  $\dim \text{Hom}(N_{\alpha\gamma}, \tau M_\beta) = 0$ ,  $\dim \text{Hom}(N_{\alpha\gamma}, \tau M_\gamma) = 1$ ,  
 $\dim \text{Hom}(N_{\alpha\gamma}, \tau N_{\alpha\beta}) = 1$ ,  $\dim \text{Hom}(N_{\alpha\gamma}, \tau N_{\alpha\gamma}) = 2$ ,  $\dim \text{Hom}(N_{\alpha\gamma}, \tau N_{\beta\gamma}) = 1$ .

$$= 1.$$

- $\dim \operatorname{Hom}(N_{\beta\gamma}, \tau M_\alpha) = 0$ ,  $\dim \operatorname{Hom}(N_{\beta\gamma}, \tau M_\beta) = 1$ ,  $\dim \operatorname{Hom}(N_{\beta\gamma}, \tau M_\gamma) = 1$ ,  $\dim \operatorname{Hom}(N_{\beta\gamma}, \tau N_{\alpha\beta}) = 1$ ,  $\dim \operatorname{Hom}(N_{\beta\gamma}, \tau N_{\alpha\gamma}) = 1$ ,  $\dim \operatorname{Hom}(N_{\beta\gamma}, \tau N_{\beta\gamma}) = 2$ .
- $\dim \operatorname{Hom}(\tau M_\alpha, \tau N_{\alpha\beta}) = 0$ ,  $\dim \operatorname{Hom}(\tau M_\alpha, \tau N_{\alpha\gamma}) = 1$ ,  $\dim \operatorname{Hom}(\tau M_\alpha, \tau N_{\beta\gamma}) = 0$ .
- $\dim \operatorname{Hom}(\tau M_\beta, \tau N_{\alpha\beta}) = 1$ ,  $\dim \operatorname{Hom}(\tau M_\beta, \tau N_{\alpha\gamma}) = 0$ ,  $\dim \operatorname{Hom}(\tau M_\beta, \tau N_{\beta\gamma}) = 1$ .
- $\dim \operatorname{Hom}(\tau M_\gamma, \tau N_{\alpha\beta}) = 0$ ,  $\dim \operatorname{Hom}(\tau M_\gamma, \tau N_{\alpha\gamma}) = 1$ ,  $\dim \operatorname{Hom}(\tau M_\gamma, \tau N_{\beta\gamma}) = 1$ .

*Remark.* From above we see that we can have a chain  $M_\alpha \hookrightarrow N_{\alpha\beta} \hookrightarrow \tau M_\beta \hookrightarrow \tau N_{\beta\gamma}$ , where each Hom-space is one-dimensional. However  $\dim \operatorname{Hom}(M_\alpha, \tau N_{\beta\gamma}) = 3$ . Written with dimension vectors, this chain of inclusions is:  $\begin{pmatrix} 1 \\ 1 \end{pmatrix}_\alpha \hookrightarrow \begin{pmatrix} 2 \\ 1 \end{pmatrix}_{\alpha\beta} \hookrightarrow \begin{pmatrix} 5 \\ 2 \end{pmatrix}_\beta \hookrightarrow \begin{pmatrix} 13 \\ 5 \end{pmatrix}_{\beta\gamma}$ .

Finally each of the following embeddings are also 1-dimensional:  $\tau M_\alpha \hookrightarrow \tau N_{\alpha\beta} \hookrightarrow \tau^2 M_\beta \hookrightarrow \tau^2 N_{\beta\gamma}$

### 9.3 Chain of elementary modules

We will closer look at the following chains of inclusions:

$$M \subset \tau(M) \subset \tau^2(M) \subset \tau^3(M) \subset \tau^4(M) \subset \dots$$

If  $M$  is an indecomposable regular module over the 3-Kronecker quiver, then for every  $i \in \mathbb{N}$ ,  $\tau^i(M)$  is also indecomposable since  $\tau$  is an equivalence in the category of regular modules. Recall that if an indecomposable module  $M$  has no non-zero regular factor modules, then any morphism  $M \rightarrow R$ , for a regular module  $R$  is either zero or injective. Since our interest lies on the chain of dimension vectors  $\mathcal{D}$  (as in chapter 7), let us start by considering the case of  $M$  being an indecomposable module with dimension vector  $\mathbf{dim}(M) = \begin{pmatrix} 1 \\ 1 \end{pmatrix}$ . Then we can show the following:

**Lemma 9.5.** *Let  $M$  be an indecomposable regular module over the 3-Kronecker quiver with dimension vector  $\mathbf{dim}(M) = \begin{pmatrix} 1 \\ 1 \end{pmatrix}$ . Then we have inclusions  $M \hookrightarrow \tau(M) \hookrightarrow \tau^2(M) \hookrightarrow \tau^3(M) \hookrightarrow \tau^4(M) \hookrightarrow \dots$*

*Proof.* We need to show that  $\dim \operatorname{Hom}(\tau^i(M), \tau^{i+1}(M)) \neq 0$  and that any  $f \in \operatorname{Hom}(\tau^i(M), \tau^{i+1}(M))$  is a monomorphism for  $i = 0, 1, 2, 3, \dots$ . Since  $\tau$  is an equivalence it is sufficient to show that  $\dim \operatorname{Hom}(M, \tau(M)) \neq 0$ . Then, since  $M$  has no non-trivial regular factor modules, any such  $f$  (if it exists) has to be a monomorphism. Using the Auslander-Reiten formula and bilinear form

on dimension vectors we have  $\langle \binom{1}{1}, \tau \binom{1}{1} \rangle = -\langle \binom{1}{1}, \binom{1}{1} \rangle = -(-1) = 1$ . Thus  $\dim \text{Hom}(\binom{1}{1}, \tau \binom{1}{1}) - \dim \text{Ext}(\binom{1}{1}, \tau \binom{1}{1}) = 1$ , but  $\dim \text{Ext}(\binom{1}{1}, \tau \binom{1}{1}) = 1$ , so  $\dim \text{Hom}(\binom{1}{1}, \tau \binom{1}{1}) = 2 \neq 0$ .  $\square$

This lemma shows that for any indecomposable module  $M'$ , such that  $\mathbf{dim}(M') = \binom{5}{2} = \Phi \binom{1}{1}$ , there exists an indecomposable module  $M$ , such that  $\mathbf{dim}(M) = \binom{1}{1}$  and  $M \subset M'$ . Note further, since  $\text{Ext}(M, M) \neq 0$ , because  $M$  is not exceptional (there are no regular exceptional modules for the 3-Kronecker quiver), we have  $\dim \text{Hom}(\binom{1}{1}, \tau^i \binom{1}{1}) \neq 0$ , for  $i \geq 0$  (as shown in [K1], section 4.8).

**Lemma 9.6.** *Let  $N$  be an indecomposable regular module over the 3-Kronecker quiver with dimension vector  $\mathbf{dim}(N) = \binom{2}{1}$ . Then we have inclusions  $N \hookrightarrow \tau N \hookrightarrow \tau^2 N \hookrightarrow \tau^3 N \hookrightarrow \tau^4 N \hookrightarrow \dots$ .*

*Proof.* Direct adaptation of proof of lemma 9.5  $\square$

**Proposition 9.7.** *Let  $M(i)$  be indecomposable regular modules over the 3-Kronecker quiver with dimension vector  $\mathbf{dim}(M(i)) = \binom{1}{1}$ , but  $M(i) \not\cong M(j)$ , for  $i \neq j$ ,  $i, j \in \mathbb{N}$ . Then we have inclusions  $M(1) \hookrightarrow \tau(M(2)) \hookrightarrow \tau^2(M(3)) \hookrightarrow \tau^3(M(4)) \hookrightarrow \tau^4(M(5)) \hookrightarrow \dots$ , and  $\dim \text{Hom}(\tau^i(M(i-1)), \tau^{i+1}(M(i))) = 1$ .*

*Proof.* It is sufficient ( $\tau$  being an equivalence) to show that  $\dim \text{Hom}(M(1), \tau(M(2))) = 1$ . Then, since  $M$  has no non-trivial regular factor modules, any such  $f$  (if it exists) has to be a monomorphism. Using the Auslander-Reiten formula and bilinear form on dimension vectors we have  $\langle \binom{1}{1}(1), \tau \binom{1}{1}(2) \rangle = -\langle \binom{1}{1}(1), \binom{1}{1}(2) \rangle = -(-1) = 1$ . Thus  $\dim \text{Hom}(\binom{1}{1}(1), \tau \binom{1}{1}(2)) - \dim \text{Ext}(\binom{1}{1}(1), \tau \binom{1}{1}(2)) = 1$ , but  $\dim \text{Ext}(\binom{1}{1}(1), \tau \binom{1}{1}(2)) = \dim \text{Ext}(\binom{1}{1}(2), \binom{1}{1}(1)) = \dim D\text{Hom}(\binom{1}{1}(2), \binom{1}{1}(1)) = 0$ , since  $M(1) \not\cong M(2)$ , so  $\dim \text{Hom}(\binom{1}{1}, \tau \binom{1}{1}) = 1$ .  $\square$

Note that for the 3-Kronecker quiver, for any indecomposable module  $N$ , such that  $\mathbf{dim}(N) = \binom{2}{1}$ , there exists an indecomposable module  $M$ , such that  $\mathbf{dim}(M) = \binom{1}{1}$  and  $M \subset N$ .

**Proposition 9.8.** *Consider the 3-Kronecker quiver and let  $M$  be an indecomposable regular module with dimension vector  $\mathbf{dim}(M) = \binom{1}{1}$  and let  $N$  be an indecomposable regular module with dimension vector  $\mathbf{dim}(N) = \binom{2}{1}$ , such that  $M \subset N$ . Then we have inclusions  $M \hookrightarrow N \hookrightarrow \tau M \hookrightarrow \tau N \hookrightarrow \tau^2 M \hookrightarrow \tau^2 N \hookrightarrow \tau^3 M \hookrightarrow \dots$ , so  $\dim \text{Hom}(\tau^i M, \tau^i N) \neq 0$ ,  $\dim \text{Hom}(\tau^j N, \tau^{j+1} M) \neq 0$ , for all  $i, j \in \mathbb{N}$ .*

*Proof.* Let  $M \xrightarrow{f} N$  be an injective map from  $M$  to  $N$  ( $N$  has no non-zero regular factor modules). We want to show that  $N \xrightarrow{g} \tau M$  exists. Consider the bilinear form on dimension vectors: Using the Auslander-Reiten formula we get  $\langle \binom{2}{1}, \tau \binom{1}{1} \rangle = -\langle \binom{1}{1}, \binom{2}{1} \rangle = -(3 - 3) = 0$ . But  $\dim \text{Hom}(M, N) \neq 0$ , so  $\dim \text{Ext}(M, N) \neq 0$ , and so  $\dim \text{Hom}(N, \tau M) \neq 0$ . Since the Auslander-Reiten translate  $\tau$  defines an equivalence on the category of regular modules and is left

exact, since we are in the hereditary situation, we have the following embeddings for  $i, j \in \mathbb{N}$ :

$$\begin{aligned}\tau^i M &\xhookrightarrow{\tau^i f} \tau^i N \\ \tau^i N &\xhookrightarrow{\tau^j g} \tau^{j+1} M\end{aligned}$$

Of course,  $\tau^i N$  and  $\tau^{j+1} M$  have no non-zero regular factor modules. □

## A Maple source code

This appendix contains two Maple programs. The first Maple procedure does the following: Given a representation  $M$  (here of the 3-Kronecker quiver), it computes the representation of  $\tau M$ . The second program draws the coefficient quiver of a given representation (here again of the 3-Kronecker quiver). These programs are fully Maple compatible and do not require additional software. Let me refer to [FKKM] if you want further graphical outputs than the standard Maple routines.

### A.1 Computing the Auslander-Reiten translate

Let us apply the first program to the concrete example of applying reflection processes to a given representation of dimension vector  $(1, 2)$  of the 3-Kronecker quiver. As input the matrices for the representation have to be supplied:

```
> alpha:=Matrix([[1,0]]): beta:=Matrix([[0,1]]): gamma0:=Matrix([[0,0]]):  
  
# Making one big matrix out of the input.  
> M:=Matrix([[alpha,beta,gamma0]]):  
  
# Calculating the kernel.  
> kerM:=kernel(M): kerMlist:=convert(kerM,list):  
  
kerM := {[0, 1, 0, 0, 0, 0], [0, 0, 1, 0, 0, 0], [-1, 0, 0, 1, 0, 0], [0, 0, 0, 0, 1, 0], [0, 0, 0, 0, 0, 1]}  
  
> AkerM:=Transpose(Matrix([ seq([kerMlist[i]], i=1..nops(kerM)) ]));  
> Zeilen:=Dimensions(AkerM)[1]/3: 3*Zeilen: Spalten:=Dimensions(AkerM)[2]:
```

$$AkerM := \begin{bmatrix} 0 & 0 & -1 & 0 & 0 \\ 1 & 0 & 0 & 0 & 0 \\ 0 & 1 & 0 & 0 & 0 \\ 0 & 0 & 1 & 0 & 0 \\ 0 & 0 & 0 & 1 & 0 \\ 0 & 0 & 0 & 0 & 1 \end{bmatrix}$$

Now get three new matrices for reflection at the first sink:

```
> alpha1:=AkerM[1..Zeilen,1..Spalten]:  
> beta1:=AkerM[Zeilen+1..2*Zeilen,1..Spalten]:  
> gamma1:=AkerM[2*Zeilen+1..3*Zeilen,1..Spalten]:  
  
# and make a big matrix out of them.  
> M2:=<alpha1 | beta1 | gamma1>;  
> kerM2:=kernel(M2): nops(kerM2); kerM2list:=convert(kerM2,list):
```

$$M2 := \begin{bmatrix} 0 & 0 & -1 & 0 & 0 & 0 & 1 & 0 & 0 & 0 & 0 & 0 & 0 & 1 & 0 \\ 1 & 0 & 0 & 0 & 0 & 0 & 0 & 1 & 0 & 0 & 0 & 0 & 0 & 0 & 1 \end{bmatrix}$$

Again, build a matrix of it:

```
> BkerM2:=Transpose(Matrix([ seq([kerM2list[j]],j=1..nops(kerM2)) ]));
> Zeilen2:=Dimensions(BkerM2)[1]/3; 3*Zeilen2: Spalten2:=Dimensions(BkerM2)[2];
```

$$BkerM2 := \begin{bmatrix} 0 & 0 & 0 & 0 & 0 & -1 & 0 & 0 & 0 & 0 & 0 & 0 & 0 & -1 \\ 1 & 0 & 0 & 0 & 0 & 0 & 0 & 0 & 0 & 0 & 0 & 0 & 0 & 0 \\ 0 & 0 & 0 & 0 & 1 & 0 & 0 & 0 & 0 & 0 & 0 & 0 & 1 & 0 \\ 0 & 1 & 0 & 0 & 0 & 0 & 0 & 0 & 0 & 0 & 0 & 0 & 0 & 0 \\ 0 & 0 & 1 & 0 & 0 & 0 & 0 & 0 & 0 & 0 & 0 & 0 & 0 & 0 \\ 0 & 0 & 0 & 1 & 0 & 0 & 0 & 0 & 0 & 0 & 0 & 0 & 0 & 0 \\ 0 & 0 & 0 & 0 & 1 & 0 & 0 & 0 & 0 & 0 & 0 & 0 & 0 & 0 \\ 0 & 0 & 0 & 0 & 0 & 1 & 0 & 0 & 0 & 0 & 0 & 0 & 0 & 0 \\ 0 & 0 & 0 & 0 & 0 & 0 & 1 & 0 & 0 & 0 & 0 & 0 & 0 & 0 \\ 0 & 0 & 0 & 0 & 0 & 0 & 0 & 1 & 0 & 0 & 0 & 0 & 0 & 0 \\ 0 & 0 & 0 & 0 & 0 & 0 & 0 & 0 & 1 & 0 & 0 & 0 & 0 & 0 \\ 0 & 0 & 0 & 0 & 0 & 0 & 0 & 0 & 0 & 1 & 0 & 0 & 0 & 0 \\ 0 & 0 & 0 & 0 & 0 & 0 & 0 & 0 & 0 & 0 & 1 & 0 & 0 & 0 \\ 0 & 0 & 0 & 0 & 0 & 0 & 0 & 0 & 0 & 0 & 0 & 1 & 0 & 0 \\ 0 & 0 & 0 & 0 & 0 & 0 & 0 & 0 & 0 & 0 & 0 & 0 & 1 & 0 \end{bmatrix}$$

Now get the three new maps for reflection at the second sink, hence we get the new representation:

```
> alpha2:=BkerM2[1..Zeilen2,1..Spalten2];
> beta2:=BkerM2[Zeilen2+1..2*Zeilen2,1..Spalten2];
> gamma2:=BkerM2[2*Zeilen2+1..3*Zeilen2,1..Spalten2];
```

$$\alpha2 := \begin{bmatrix} 0 & 0 & 0 & 0 & 0 & -1 & 0 & 0 & 0 & 0 & 0 & 0 & 0 & -1 \\ 1 & 0 & 0 & 0 & 0 & 0 & 0 & 0 & 0 & 0 & 0 & 0 & 0 & 0 \\ 0 & 0 & 0 & 0 & 1 & 0 & 0 & 0 & 0 & 0 & 0 & 0 & 1 & 0 \\ 0 & 1 & 0 & 0 & 0 & 0 & 0 & 0 & 0 & 0 & 0 & 0 & 0 & 0 \\ 0 & 0 & 1 & 0 & 0 & 0 & 0 & 0 & 0 & 0 & 0 & 0 & 0 & 0 \end{bmatrix}$$

$$\beta2 := \begin{bmatrix} 0 & 0 & 0 & 1 & 0 & 0 & 0 & 0 & 0 & 0 & 0 & 0 & 0 & 0 \\ 0 & 0 & 0 & 0 & 1 & 0 & 0 & 0 & 0 & 0 & 0 & 0 & 0 & 0 \\ 0 & 0 & 0 & 0 & 0 & 1 & 0 & 0 & 0 & 0 & 0 & 0 & 0 & 0 \\ 0 & 0 & 0 & 0 & 0 & 0 & 1 & 0 & 0 & 0 & 0 & 0 & 0 & 0 \\ 0 & 0 & 0 & 0 & 0 & 0 & 0 & 1 & 0 & 0 & 0 & 0 & 0 & 0 \end{bmatrix}$$

$$\gamma_2 := \begin{bmatrix} 0 & 0 & 0 & 0 & 0 & 0 & 0 & 0 & 0 & 1 & 0 & 0 & 0 & 0 \\ 0 & 0 & 0 & 0 & 0 & 0 & 0 & 0 & 0 & 0 & 1 & 0 & 0 & 0 \\ 0 & 0 & 0 & 0 & 0 & 0 & 0 & 0 & 0 & 0 & 0 & 1 & 0 & 0 \\ 0 & 0 & 0 & 0 & 0 & 0 & 0 & 0 & 0 & 0 & 0 & 0 & 1 & 0 \\ 0 & 0 & 0 & 0 & 0 & 0 & 0 & 0 & 0 & 0 & 0 & 0 & 0 & 1 \end{bmatrix}$$

Thus having started with a representation  $M$  the program computed the matrices for the representation  $\tau M$ . We are left to draw the coefficient quiver of this (or any) representation, which is done by the second program.

## A.2 Plotting coefficient quivers

This procedure will draw different coefficient quivers from a given representation. Here we take the example of an indecomposable representation of dimension vector (2, 5) for the 3-Kronecker quiver. We begin with giving as input the three matrices for the arrows of the quiver:

```
> AL:= Matrix([[1, 0, 0, 0, 0], [0, 1, 0, 0, 0]]):
> BE := Matrix( [[0, 0, 0, 0, -1], [0, 0, 1, 0, 0]]):
> GA := Matrix([[0, 0, 0, 1, 0], [0, 0, 0, 0, 1]]):

# Make a big matrix out of these.
> BkerM2:=<AL,BE,GA>;
> zeilen2:=Dimensions(BkerM2)[1]/3: spalten:=Dimensions(BkerM2)[2]:
```

$$BkerM2 := \begin{bmatrix} 1 & 0 & 0 & 0 & 0 \\ 0 & 1 & 0 & 0 & 0 \\ 0 & 0 & 0 & 0 & -1 \\ 0 & 0 & 1 & 0 & 0 \\ 0 & 0 & 0 & 1 & 0 \\ 0 & 0 & 0 & 0 & 1 \end{bmatrix}$$

To draw the graph we have to define vertex set and arrow set of the coefficient quiver, which is simply an oriented graph.

```
> alpha2:=BkerM2[1..zeilen2,1..spalten]:
> beta2:=BkerM2[zeilen2+1..2*zeilen2,1..spalten]:
> gamma2:=BkerM2[2*zeilen2+1..3*zeilen2,1..spalten]:
> VerwMatrix:=BkerM2: Dimm:=Dimensions(VerwMatrix):
> Dimmalpha:=Dimensions(alpha2): Dimmbeta:=Dimensions(beta2):
> Dimmgamma:=Dimensions(gamma2):
> Schritte:=Dimensions(alpha2)[1]:
> alphabet:=seq(k,k="a".."z"):
> vertexset1:={seq(v[i],i=1..Dimm[1])}: vertexset2:={seq(i,i=1..Dimm[2])};
```

$$vertexset2 := \{1, 2, 3, 4, 5\}$$

Now define the algorithm to translate the matrix information into a graph, by first sorting out vertices and edges.

```
> vertexset1schritte:={}:
> for i from 1 to Dimm[1]
  do vertexset1schritte:=vertexset1schritte,v[(i+1 mod Schritte)+1] od:
> dummy:=seq(vertexset1schritte[i],i=2..Schritte+1):
> vertexset1:=convert({dummy},set): vertexset:=vertexset1 union vertexset2:
> vertexsetlist1:=convert(vertexset1,list):
```

```

vertexsetlist2:=convert(vertexset2,list):
> vertexsetlist:=convert(vertexset,list):
> vertexset1alphabet:={seq(k,k="a"..alphabet[nops(vertexset1)])}:
> vertexsetalphabet:=vertexset1alphabet union vertexset2:
> vertexsetlist1alphabet:=convert(vertexset1alphabet,list):
> vertexsetlistalphabet:=convert(vertexsetalphabet,list):

```

$$\begin{aligned}
\text{vertexset} &:= \{1, 2, 3, 4, 5, v[1], v[2]\} \\
\text{vertexsetlist1} &:= [v[1], v[2]] \\
\text{vertexsetlist2} &:= [1, 2, 3, 4, 5]
\end{aligned}$$

Now determine the connecting information between the vertices.

```

> edges:=[0,0]: edgesset:={0}: z:=1:
> edgesalsset:={0,0}: edgesw:=[0,0]: edgesetw:={0}: zw:=1:
> for i from 1 to Dimm[1] do
>   for j from 1 to Dimm[2] do
>     if VerwMatrix[i,j]<>0 then
>       edges:=edges,[alphabet[(i+1 mod Schritte)+1],j];
edgesalsset:=edgesalsset,{alphabet[(i+1 mod Schritte)+1],j};
>       edgesset:=edgesset,{alphabet[(i+1 mod Schritte)+1],j};
>       z:=z+1; edgesw:=edgesw,[alphabet[(i+1 mod Schritte)+1],j]=VerwMatrix[i,j];
>
>     if (type(VerwMatrix[i,j],symbol) or type(VerwMatrix[i,j],‘*‘)) then
>       edgesetw:=edgesetw,[{alphabet[(i+1 mod Schritte)+1],j},8.8]:
>     else
>       edgesetw:=edgesetw,[{alphabet[(i+1 mod Schritte)+1],j},VerwMatrix[i,j]]:
>     fi;
>     zw:=zw+1; fi; od; od;
>
> z-1; nops({edges})-1; edges[1]; edgesset[1];
> edgelist:=[seq(edges[i],i=2..z)];
> edgelistalsset:=[seq(edgesalsset[i],i=2..z)]:
> edgeset:={seq(edgesset[i],i=2..z)};
> nops(edgelist); nops(edgeset);
>
> if zw-1<>nops({edgesw})-1 then print("ERROR"); fi; edgesw[1]; edgesetw[1];
> edgelistw:=[seq(edgesw[i],i=2..zw)];
> edgesetw:={seq(edgesetw[i],i=2..zw)};

```

We get in this case the following connection information:

$$\begin{aligned}
\text{edgelist} &:= [{"a", 1}, {"b", 2}, {"a", 5}, {"b", 3}, {"a", 4}, {"b", 5}] \\
\text{edgeset} &:= \{\{1, "a"\}, \{2, "b"\}, \{5, "a"\}, \{3, "b"\}, \{4, "a"\}, \{5, "b"\}\}
\end{aligned}$$

Then we sort out the list for each arrow individually:

```

> for ik from 1 to nops(edgelist) do
>   for ikl from 1 to nops(edgelist) do
>     if ik<>ikl then if edgelist[ik]=edgelist[ikl] then
>       print("Edgelist position:",ikl,"Double egde:", edgelist[ikl]); fi fi od od;

> edgesalpha:=[0,0]: edgessetalpha:={0}: zalpha:=1:
> edgesalssetalpha:={0,0}: edgeswalpha:=[0,0]: edgessetwalpha:={0}:
>   zwalpha:=1:
> for i from 1 to Dimmalpha[1] do
>   for j from 1 to Dimmalpha[2] do
>     if alpha2[i,j]<>0 then
edgesalpha:=edgesalpha,[alphabet[(i+1 mod Schritte)+1],j];
edgesalssetalpha:=edgesalssetalpha,{alphabet[(i+1 mod Schritte)+1],j};
edgessetalpha:=edgessetalpha,{alphabet[(i+1 mod Schritte)+1],j};
zalpha:=zalpha+1;
edgeswalpha:=edgeswalpha,[alphabet[(i+1 mod Schritte)+1],j]=alpha2[i,j];
> if (type(alpha2[i,j],symbol) or type(alpha2[i,j],'*')) then
> edgessetwalpha:=edgessetwalpha,[{alphabet[(i+1 mod Schritte)+1],j},3.3]:
> else
> edgessetwalpha:=edgessetwalpha,
  [{alphabet[(i+1 mod Schritte)+1],j},alpha2[i,j]]: fi;
> zwalpha:=zwalpha+1; fi; od; od;
>
> zalpha-1; nops({edgesalpha})-1; edgesalpha[1]; edgessetalpha[1];
  edgelistalpha:=[seq(edgesalpha[i],i=2..zalpha)];
> edgelistalssetalpha:=[seq(edgesalssetalpha[i],i=2..zalpha)]:
  edgesetalpha:={seq(edgessetalpha[i],i=2..zalpha)};
> nops(edgelistalpha); nops(edgesetalpha);
>
> print("weights alpha:");
> if zwalpha-1<>nops({edgeswalpha})-1 then print("ERROR"); fi;
edgeswalpha[1]; edgessetwalpha[1];
edgelistwalpha:=[seq(edgeswalpha[i],i=2..zwalpha)];
edgesetwalpha:={seq(edgessetwalpha[i],i=2..zwalpha)};

      edgelistalpha := [[ "a", 1], [ "b", 2]]
      edgelistwalpha := [[ "a", 1] = 1, [ "b", 2] = 1]

```

And similarly for  $\beta$  and  $\gamma$ .

We are now ready to plot the pictures. For this we use the Maple package *networks*, which is supplied with Maple.

```

> with(networks):
> G:=graph(vertexsetlistalphabet,edgeset):
> Galpha:=graph(vertexsetlistalphabet,edgesetalpha):

```

```

> Gbeta:=graph(vertexsetlistalphabet,edgesetbeta):
> Ggamma:=graph(vertexsetlistalphabet,edgesetgamma):
> # draw(G); # draw(Galpha); draw(Gbeta); draw(Ggamma);
> # draw(Concentric(vertexsetlist1alphabet),G);
> draw(Linear(vertexsetlist1alphabet),G);
> draw(Linear(vertexsetlist1alphabet),Galpha);
  draw(Linear(vertexsetlist1alphabet),Gbeta);
  draw(Linear(vertexsetlist1alphabet),Ggamma);

```

Finally we get a first picture of a coefficient quiver as drawn by Maple:

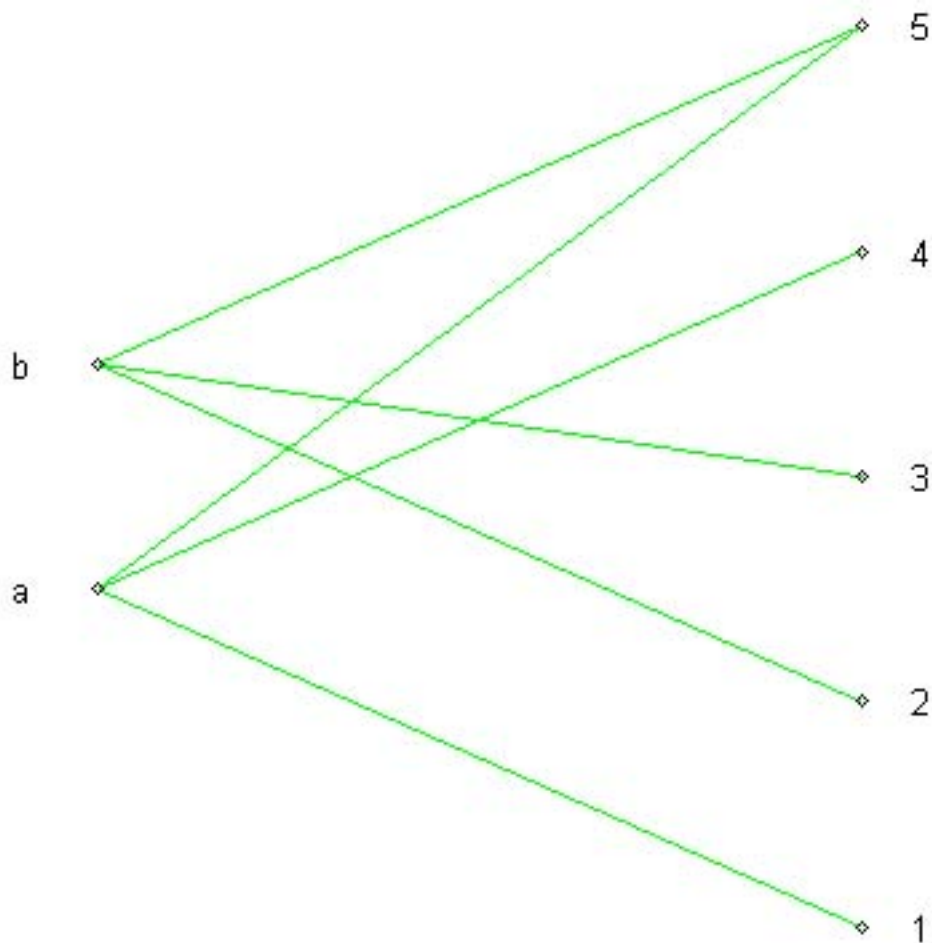

Figure 7: A coefficient quiver as drawn by Maple for dimension vector  $(2, 5)$ .

It is possible to improve the display of these coefficient quiver by well positioning the vertices to get pictures similar to those of chapter 9.2. This is best achieved by using the routines from [FKKM], which are freely accessible on their webpages. Let me finally point out that the above programs can be easily adapted to more general quivers.

## References

- [ARS] M. Auslander, I. Reiten, S. Smalø: *Representation Theory of Artin Algebras*. Cambridge University Press, 1995.
- [ASS] I. Assem, D. Simson, A. Skowronski: *Elements of the representation theory of as- sociative algebras*. I: Techniques of Representation Theory, London Mathematical Society Student Texts 65, Cambridge University Press, 2006.
- [BGP] I. N. Bernstein, I. M. Gelfand, V. A. Ponomarev: *Coxeter functors and Gabriel's theorem*, Uspechi Mat. Nauk. 28, 1973, 19-33; Russian Math. Surveys 29, 1973, 17-32.
- [CB] W. Crawley-Boevey: *Lectures on representations of quivers; More lectures on representations of quivers*. Lecture Notes, Oxford University, 1992.
- [CB2] W. Crawley-Boevey: *Infinite-dimensional modules in the representation theory of finite-dimensional algebras*. Canadian Math. Soc. Conf. Proc. 23, 1998, 29-54.
- [DR] V. Dlab, C.M. Ringel: *Indecomposable representations of graphs and algebras*. Memoirs Amer. Math. Soc. (6) 173, 1976.
- [FR] P. Fahr, C.M. Ringel: *A Partition Formula for Fibonacci Numbers*. Journal of Integer Sequences, Article 08.1.4, Vol. 11, 2008.
- [FKKM] J. Farr, M. Khatirinejad, S. Khodadad, M. Monagan: *A Graph Theory Package for Maple*, preprint, Simon Fraser University, Burnaby, Canada.
- [G1] P. Gabriel: *Indecomposable Representations II*. Symposia Mathematica, Vol. XI, Academic Press, London/New York, 1973, 81-104.
- [G2] P. Gabriel: *The universal cover of a representation-finite algebra*, in Representations of Algebras (Puebla, 1980), Springer Lecture Notes in Math., vol. 903, 1981, 68-105.
- [Ka1] V.G. Kac: *Infinite root systems, representations of graphs and invariant theory*. Invent. Math. 56(1), 1980, 57-92.
- [Ka2] V.G. Kac: *Root systems, representations of quivers and invariant theory*, in: Invariant Theory, Montecatini, Springer Lecture Notes in Math. 996, 1982, 74-108.
- [K1] O. Kerner: *Representations of wild quivers*. CMS Conf. Proc. 19, 1996, 65-107.
- [K2] O. Kerner: *Basic results on wild hereditary algebras*. AMS Contemp. Math. 229, 1998, 215-225.

- [KR] H.P. Kraft, Ch. Riedtmann: *Geometry of Representations of Quivers*. Representation of Algebras, Proc. Durham 1985, London Math. Soc. Lecture Note Series 116, CUP, 1986, 109-145.
- [Kr1] H. Krause: *An axiomatic characterization of the Gabriel-Roiter measure*. Bull. London Math. Soc., 2007.
- [Kr2] H. Krause: *Representations of quivers via reflection functors*. Lecture Notes, University of Paderborn, 2007.
- [L1] F. Lukas: *Infinite dimensional modules over wild hereditary algebras*. J. London Math. Soc. 44, 1991, 401-419.
- [L2] F. Lukas: *Elementare Moduln über wilden erblichen Algebren*. Dissertation, Düsseldorf, 1992.
- [Ri1] C.M. Ringel: *Exceptional Modules are Tree Modules*. Lin. Alg. Appl. 275-276, 1998, 471-493.
- [Ri2] C.M. Ringel: *Finite-dimensional hereditary algebras of wild representation type*. Math. Z. 161, 1978, 235-255.
- [Ri3] C.M. Ringel: *The Gabriel-Roiter Measure*. Bull. Sci. math. 129, 2005, 726-748.
- [Ri4] C.M. Ringel: *Foundation of the Representation Theory of Artin Algebras, Using the Gabriel-Roiter Measure*. In: Trends in Representation Theory of Algebras and Related Topics. (Proceedings Queretaro Workshop ICRA 2004, Mexico). Edited by de la Pena and Bautista. Contemporary Math. 406. Amer.Math.Soc., 2006, 105-135.
- [Ri5] C.M. Ringel: *Infinite dimensional representations of finite dimensional hereditary algebras*. Symposia Math. 23, 1979, 321-412.
- [Ri6] C.M. Ringel: *Pillars*, Selected Topics in Representation Theory, University of Bielefeld, 2006.
- [Ri7] C.M. Ringel: *Reflection Functors for Hereditary Algebras*. J. London Math. Soc. (2), 21, 1980, 465-479.
- [Ri8] C.M. Ringel: *Representations of  $K$ -species and bimodules*. J. Algebra 41, 1976, 269-302.
- [Ri9] C.M. Ringel: *Tame algebras and integral quadratic forms*. Springer Lecture Notes in Math. 1099, 1984.
- [S] N. J. A. Sloane: *The On-Line Encyclopedia of Integer Sequences*. <http://www.research.att.com/~njas/sequences/>